

Artikelnummer	Beschreibung
F3	Feder für starke Belastung

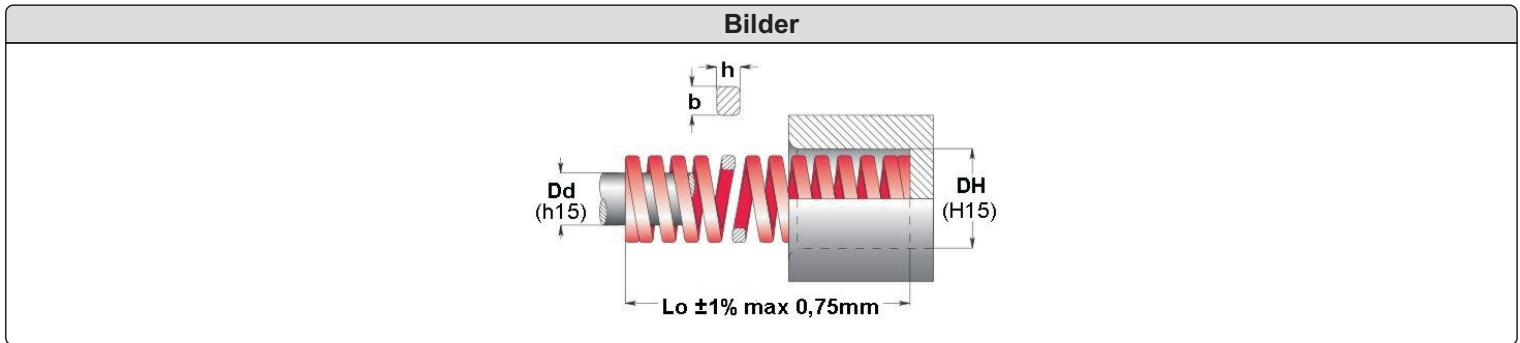



Informationen
Baugleich Fibro 241.16. Farbe Rot



Abmessungen
Siehe nächste Seite

Bestellbeispiel
F-20102-3 = F- Durchmesser DH 20mm, Länge Lo 102mm, Rot

Code	D_H	D_d	L_0	R	A	B	C	D	E				
	b x h			$\pm 10\%$									
	mm	mm	mm	N/mm	+ 3.000.000	~ 1.500.000	300 - 500.000	100 - 200.000	nicht verwenden				
					mm	N	mm	N	mm				
F-10025-3			25	22.1	5.0	111	6.3	139	6.9	152	7.5	166	9.2
F-10032-3			32	17.5	6.4	112	8.0	140	8.8	154	9.6	168	12.1
F-10038-3			38	17.1	7.6	130	9.5	162	10.5	179	11.4	195	13.2
F-10044-3	10	5	44	15.0	8.8	132	11.0	165	12.1	182	13.2	198	15.1
F-10051-3			51	12.8	10.2	131	12.8	164	14.0	180	15.3	196	19.5
F-10064-3			64	10.7	12.8	137	16.0	171	17.6	188	19.2	205	21.8
F-10076-3			76	7.5	15.2	114	19.0	143	20.9	157	22.8	171	27.9
F-10305-3	1.9 x 1.5		305	2.1	61.0	128	76.3	160	83.9	176	91.5	192	127
F-13025-3			25	42.1	5.0	211	6.3	265	6.9	289	7.5	316	9.8
F-13032-3			32	33.2	6.4	212	8.0	266	8.8	292	9.6	319	13.6
F-13038-3			38	29.3	7.6	223	9.5	278	10.5	306	11.4	334	14.6
F-13044-3	12.5	6.3	44	24.6	8.8	216	11.0	271	12.1	298	13.2	325	18.1
F-13051-3			51	19.6	10.2	200	12.8	251	14.0	275	15.3	300	22.3
F-13064-3			64	15.0	12.8	192	16.0	240	17.6	264	19.2	288	27.3
F-13076-3			76	13.2	15.2	201	19.0	251	20.9	276	22.8	301	33.1
F-13089-3			89	11.4	17.8	203	22.3	254	24.5	279	26.7	304	38.9
F-13102-3			102	8.4	20.4	171	25.5	214	28.1	236	30.6	257	43.8
F-13305-3	2.4 x 1.9		305	2.8	61.0	171	76.3	214	83.9	235	91.5	256	140

Code	D _H	D _d	L ₀	R	A		B		C		D		E	
					 20% L ₀	N	 25% L ₀	N	 27.5% L ₀	N	 30% L ₀	N	 max.	
b x h			± 10%	+ 3.000.000	~ 1.500.000	300 - 500.000	100 - 200.000	nicht verwenden						
mm mm		mm	N/mm	mm	N	mm	N	mm	N	mm	N	mm		
F-16025-3	16	8	25	75.7	5.0	379	6.3	477	6.9	520	7.5	568	8.4	
F-16032-3			32	52.8	6.4	338	8.0	422	8.8	465	9.6	507	10.5	
F-16038-3			38	48.5	7.6	369	9.5	461	10.5	507	11.4	553	13.6	
F-16044-3			44	42.8	8.8	377	11.0	471	12.1	518	13.2	565	15.9	
F-16051-3			51	37.1	10.2	378	12.8	475	14.0	520	15.3	568	18.9	
F-16064-3			64	30.3	12.8	388	16.0	485	17.6	533	19.2	582	24.9	
F-16076-3			76	25.7	15.2	391	19.0	488	20.9	537	22.8	586	29.2	
F-16089-3			89	21.7	17.8	386	22.3	484	24.5	531	26.7	579	34.5	
F-16102-3			102	19.3	20.4	394	25.5	492	28.1	541	30.6	591	39.1	
F-16115-3			115	15.7	23.0	361	28.8	452	31.6	497	34.5	542	44.0	
F-16305-3			3.1 x 2.5	305	7.1	61.0	433	76.3	542	83.9	596	91.5	650	104
F-20025-3	20	10	25	216	5.0	1080	6.3	1361	6.9	1485	7.5	1620	8.3	
F-20032-3			32	168	6.4	1075	8.0	1344	8.8	1478	9.6	1613	10.9	
F-20038-3			38	129	7.6	980	9.5	1226	10.5	1348	11.4	1471	12.5	
F-20044-3			44	112	8.8	986	11.0	1232	12.1	1355	13.2	1478	15.0	
F-20051-3			51	94.0	10.2	959	12.8	1203	14.0	1318	15.3	1438	17.6	
F-20064-3			64	72.1	12.8	923	16.0	1154	17.6	1269	19.2	1384	22.6	
F-20076-3			76	59.7	15.2	907	19.0	1134	20.9	1248	22.8	1361	27.5	
F-20089-3			89	50.5	17.8	899	22.3	1126	24.5	1236	26.7	1348	31.7	
F-20102-3			102	44.2	20.4	902	25.5	1127	28.1	1240	30.6	1353	37.5	
F-20115-3			115	38.4	23.0	883	28.8	1106	31.6	1214	34.5	1325	42.6	
F-20127-3			127	34.1	25.4	866	31.8	1084	34.9	1191	38.1	1299	45.5	
F-20139-3			139	31.0	28.0	868	35.0	1085	38.2	1185	42.0	1302	50.1	
F-20152-3			152	28.2	30.4	857	38.0	1072	41.8	1179	45.6	1286	55.8	
F-20305-3			4.0 x 3.3	305	15.0	61.0	915	76.3	1145	83.9	1258	91.5	1373	114
F-25025-3	25	12.5	25	375	5.0	1875	6.3	2363	6.9	2578	7.5	2813	8.5	
F-25032-3			32	297	6.4	1901	8.0	2376	8.8	2614	9.6	2851	11.0	
F-25038-3			38	219	7.6	1664	9.5	2081	10.5	2289	11.4	2497	12.6	
F-25044-3			44	187	8.8	1646	11.0	2057	12.1	2263	13.2	2468	14.8	
F-25051-3			51	156	10.2	1591	12.8	1997	14.0	2188	15.3	2387	17.9	
F-25064-3			64	123	12.8	1574	16.0	1968	17.6	2165	19.2	2362	23.1	
F-25076-3			76	99.0	15.2	1505	19.0	1881	20.9	2069	22.8	2257	26.3	
F-25089-3			89	84.0	17.8	1495	22.3	1873	24.5	2056	26.7	2243	30.5	
F-25102-3			102	73.0	20.4	1489	25.5	1862	28.1	2048	30.6	2234	37.3	
F-25115-3			115	65.0	23.0	1495	28.8	1872	31.6	2056	34.5	2243	41.9	
F-25127-3			127	57.7	25.4	1466	31.8	1835	34.9	2015	38.1	2198	46.2	
F-25139-3			139	52.7	28.0	1476	35.0	1845	38.2	2014	42.0	2213	49.3	
F-25152-3			152	47.8	30.4	1453	38.0	1816	41.8	1998	45.6	2180	55.7	
F-25178-3			178	41.0	35.6	1460	44.5	1825	49.0	2007	53.4	2189	65.1	
F-25203-3			203	35.8	40.6	1453	50.8	1819	55.8	1999	60.9	2180	74.5	
F-25305-3			5.5 x 4.2	305	22.9	61.0	1397	76.3	1747	83.9	1921	91.5	2095	110

Code	D _H	D _d	L ₀	R	A		B		C		D		E		
					20% L ₀	N	25% L ₀	N	27.5% L ₀	N	30% L ₀	N	max.		
b x h		± 10%		+ 3.000.000		~ 1.500.000		300 - 500.000		100 - 200.000		nicht verwenden			
mm mm		mm N/mm		mm N		mm N		mm N		mm N		mm			
F-32038-3	32	16	38	388	7.6	2949	9.5	3686	10.5	4055	11.4	4423	12.5		
F-32044-3			44	324	8.8	2851	11.0	3564	12.1	3920	13.2	4277	14.9		
F-32051-3			51	272	10.2	2774	12.8	3482	14.0	3815	15.3	4162	17.8		
F-32064-3			64	212	12.8	2714	16.0	3392	17.6	3731	19.2	4070	22.4		
F-32076-3			76	172	15.2	2614	19.0	3268	20.9	3595	22.8	3922	26.1		
F-32089-3			89	141	17.8	2510	22.3	3144	24.5	3451	26.7	3765	30.8		
F-32102-3			102	122	20.4	2489	25.5	3111	28.1	3422	30.6	3733	36.8		
F-32115-3			115	107	23.0	2461	28.8	3082	31.6	3384	34.5	3692	41.4		
F-32127-3			127	93.0	25.4	2362	31.8	2957	34.9	3248	38.1	3543	44.4		
F-32139-3			139	86.0	28.0	2408	35.0	3010	38.2	3287	42.0	3612	48.5		
F-32152-3			152	78.0	30.4	2371	38.0	2964	41.8	3260	45.6	3557	54.8		
F-32178-3			178	67.2	35.6	2392	44.5	2990	49.0	3289	53.4	3588	63.6		
F-32203-3			203	59.1	40.6	2399	50.8	3002	55.8	3299	60.9	3599	72.5		
F-32254-3			254	46.4	50.8	2357	63.5	2946	69.9	3241	76.2	3536	92.8		
F-32305-3			7.1 x 5.4	305	38.0	61.0	2318	76.3	2899	83.9	3187	91.5	3477	112	
F-40051-3	40	20	51	350	10.2	3570	12.8	4480	14.0	4909	15.3	5355	17.0		
F-40064-3			64	269	12.8	3443	16.0	4304	17.6	4734	19.2	5165	21.9		
F-40076-3			76	219	15.2	3329	19.0	4161	20.9	4577	22.8	4993	26.7		
F-40089-3			89	190	17.8	3382	22.3	4237	24.5	4650	26.7	5073	31.3		
F-40102-3			102	163	20.4	3325	25.5	4157	28.1	4572	30.6	4988	37.1		
F-40115-3			115	142	23.0	3266	28.8	4090	31.6	4491	34.5	4899	41.0		
F-40127-3			127	128	25.4	3251	31.8	4070	34.9	4470	38.1	4877	46.5		
F-40139-3			139	115	28.0	3220	35.0	4025	38.2	4396	42.0	4830	53.1		
F-40152-3			152	105	30.4	3192	38.0	3990	41.8	4389	45.6	4788	56.1		
F-40178-3			178	89	35.6	3168	44.5	3961	49.0	4357	53.4	4753	67.4		
F-40203-3			203	77	40.6	3126	50.8	3912	55.8	4299	60.9	4689	76.2		
F-40254-3			254	61	50.8	3099	63.5	3874	69.9	4261	76.2	4648	96.2		
F-40305-3			8.4 x 6.2	305	51	61.0	3111	76.3	3891	83.9	4278	91.5	4667	115	
F-50064-3			50	25	64	413	12.8	5286	16.0	6608	17.6	7269	19.2	7930	22.4
F-50076-3					76	339	15.2	5153	19.0	6441	20.9	7085	22.8	7729	26.5
F-50089-3	89	288			17.8	5126	22.3	6422	24.5	7049	26.7	7690	31.5		
F-50102-3	102	245			20.4	4998	25.5	6248	28.1	6872	30.6	7497	37.6		
F-50115-3	115	215			23.0	4945	28.8	6192	31.6	6799	34.5	7418	42.7		
F-50127-3	127	192			25.4	4877	31.8	6106	34.9	6706	38.1	7315	47.5		
F-50139-3	139	168			28.0	4704	35.0	5880	38.2	6422	42.0	7056	51.8		
F-50152-3	152	154			30.4	4682	38.0	5852	41.8	6437	45.6	7022	57.8		
F-50178-3	178	134			35.6	4770	44.5	5963	49.0	6559	53.4	7156	68.5		
F-50203-3	203	117			40.6	4750	50.8	5944	55.8	6532	60.9	7125	77.6		
F-50254-3	254	89			50.8	4521	63.5	5652	69.9	6217	76.2	6782	97.9		
F-50305-3	11.1 x 7.6	305			73	61.0	4453	76.3	5570	83.9	6123	91.5	6680	121	
F-63076-3	63	38			76	618	15.2	9394	19.0	11742	20.9	12916	22.8	14090	24.7
F-63089-3					89	515	17.8	9167	22.3	11485	24.5	12605	26.7	13751	30.0
F-63102-3					102	438	20.4	8935	25.5	11169	28.1	12286	30.6	13403	35.1
F-63115-3			115	370	23.0	8510	28.8	10656	31.6	11701	34.5	12765	37.5		
F-63127-3			127	333	25.4	8458	31.8	10589	34.9	11630	38.1	12687	45.9		
F-63152-3			152	269	30.4	8178	38.0	10222	41.8	11244	45.6	12266	56.5		
F-63178-3			178	226	35.6	8046	44.5	10057	49.0	11063	53.4	12068	66.8		
F-63203-3			203	198	40.6	8039	50.8	10058	55.8	11053	60.9	12058	78.8		
F-63254-3			254	155	50.8	7874	63.5	9843	69.9	10827	76.2	11811	102		
F-63305-3			11.6 x 12.3	305	128	61.0	7808	76.3	9766	83.9	10736	91.5	11712	122	

Lebensdauer: ca. 100.000 Zyklen