

CAMMA M/ML

TRINCIATURA MECCANICA
 MECHANIC SHEARING
 MECHANISCHE STANZEINHEIT/SCHIEBER
 CARROS DE PUNZONADO

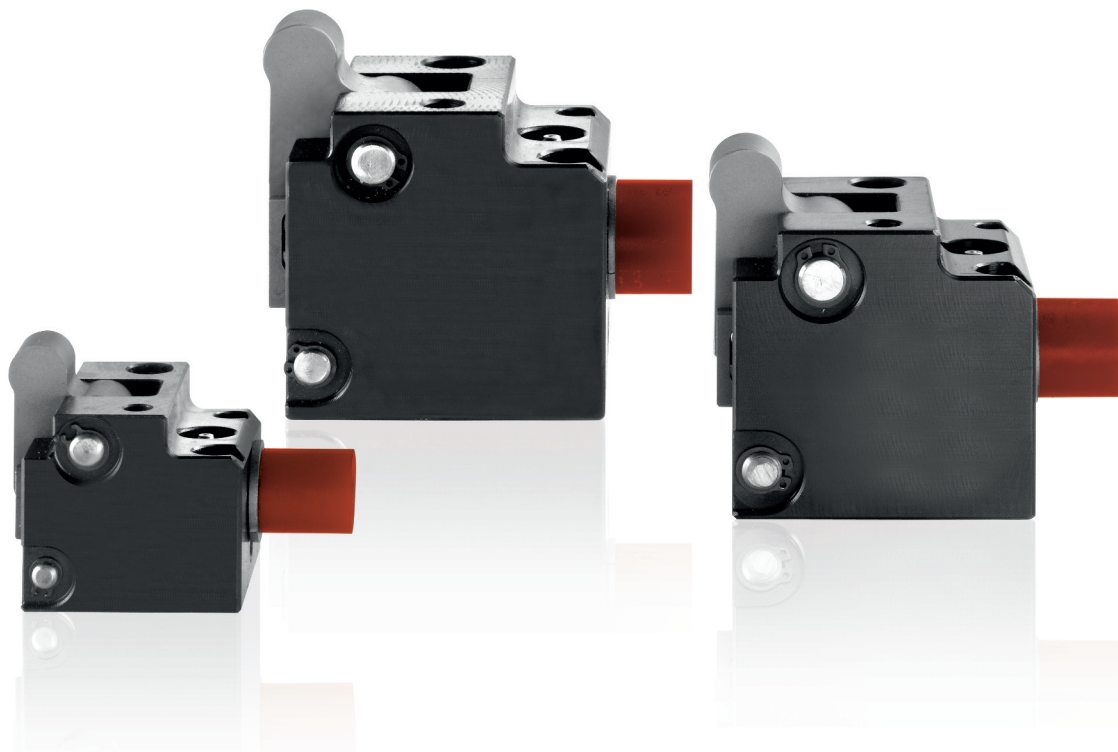

Camma meccanica contenente un punzone ricavato da uno standard ISO 8020 di potenza fino a 5000 daN con ritorno mediante molla in acciaio. M ha corsa normale, ML ha corsa lunga identificabile nel catalogo con la lettera "C". L'estrazione dalla lamiera è fatta tramite gomma PU. Può essere montata in posizione orizzontale o inclinata (previo confronto con l'ufficio tecnico Newstark). Possibili applicazioni: adatta a lavori generalmente di trinciatura e foratura.

Mechanical cam which contains a punch made from an ISO 8020 standard power supply up to 5000 daN with steel spring return. M normal stroke, ML long stroke identifiable in the catalog with the letter "C". The extraction from metal sheet is made by gummy-PU. Can be fitted horizontally or inclined (after comparison with Newstark's technical department). Means of application: generally suitable for cutting and drilling work.

Mechanische Stanzeinheit, die einen Schneidstempel nach ISO 8020 enthält, mit einer Kraft bis 5000 daN mit einem Rücklauf, der durch eine Stahlfeder sichergestellt wird. Modell M hat normalen Hub, Modell ML hat einen längeren Hub, wie man im Katalog unter dem Buchstaben "C" in der Tabelle sehen kann. Das Blech wird durch eine PU-Feder abgestreift. Die Einheiten können (nach Abstimmung mit dem technische Büro von Newstark) horizontal oder geneigt montiert werden. Mögliche Anwendungen: Prägen und Lochen.

Unidad de punzonado de hasta 5000 daN, con punzón standard ISO 8020 y retorno con muelle de acero. Modelo M para largos normales y ML para largas distancias como indica el catálogo bajo la letra "C". La extracción se efectúa por mediación de un taco de poliuretano. Se puede montar horizontalmente o inclinado (después de la comparación con el departamento técnico de Newstark). Indicado para trabajos de corte y perforación.

CAMMA M/ML



ML

M

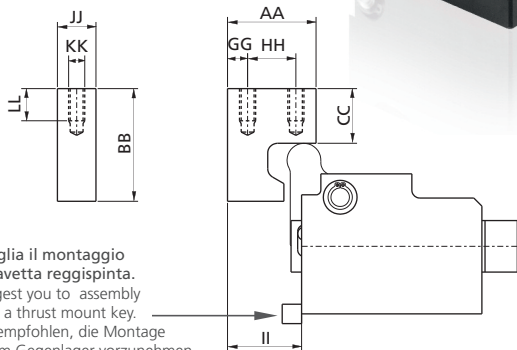

Si consiglia il montaggio con chavetta reggispinta.
We suggest you to assembly by using a thrust mount key.
Es wird empfohlen, die Montage mit einem Gegenlager vorzunehmen.
Se aconseja el montaje siempre con el pasador.

Tabella incudini con estrazione meccanica garantita.
Anvils-Table with Mechanical Extraction Guaranteed.
Druckstücke-Tabelle mit fester Rückzugskraft.
Yunques-tabla con extracción mecánica garantizada.

MODELLO - MODEL - MODELL - MODELO	AA	BB	CC	GG	HH	II	JJ	KK	LL
170	M	30	45	21	6	18	25	15	M6 16
	ML	30	45	21	6	18	25	15	M6 16
210	M	50	60	29	10	30	41,5	22	M8 20
	ML	50	60	29	10	30	41,5	22	M8 20
320	M	55	70	34	12,5	30	46	24	M10 20
	ML	55	70	34	12,5	30	46	24	M10 20

Quando c'è un'applicazione inclinata, dovremmo fornire il particolare speciale 002 "Leva" non compreso nella fornitura standard.

When slope application is present, we supply special part 002 "Lever", which is not included in the standard supply.

Bei geneigter Anwendung ist das Teil 002 als "Sondernocke" erforderlich, das in der Standardlieferung nicht vorgesehen ist.

Cuando el montaje es inclinado se debe suministrar una leva especial 002 "leva", no incluida en el suministro standard.

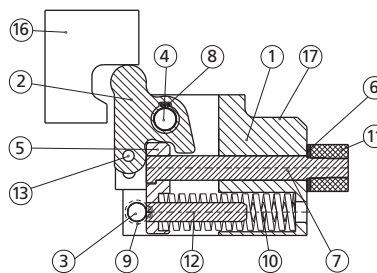
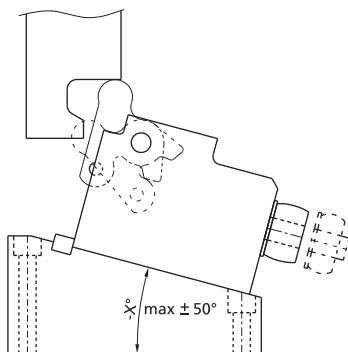
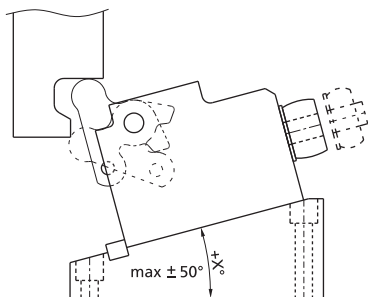

POSIZIONE - POSITION - POSICION	QUANTITÀ - QUANTITY - MENGE - CANTIDAD	DESCRIZIONE - DESCRIPTION - BESCHREIBUNG - DESCRIPCIÓN
001	1	Corpo camma / Cam body / Grundgehäuse / Cuerpo
002	1	Leva / Lever / Nocke / Leva
003	1	Perno / Pin / Stift / Perno
004	1	Perno / Pin / Achse / Perno
005	1	Porta punzone / Gate punch / Stempelhalteplatte / Portapunzón
006	1	Rondella / Washer / Unterlegscheibe / Arandela
007	1	Punzone ISO 8020 / Punch / Lochstempel / Punzón
008	2	Seeger / Seeger / Seegerring / Seger
009	2	Seeger / Seeger / Seegerring / Seger
010	1	Molla / Spring / Feder / Muelle
011	1	Molla in gomma / Rubber spring / Abstreiffeder / Muelle de goma
012	1	Perno / Pin / Federführungsstift / Perno
013	1	Perno / Pin / Anschlagstift / Perno
016*	1	Incudine / Anvil / Treiber / Yunque
017	1	Ingrassatore / Nipples / Schmierung / Engrasador

* OPTIONAL DA RICHIEDERE IN FASE D'ORDINE - OPTIONAL TO BE REQUESTED DURING ORDER
IST ALS OPTION ERHÄLTICH - OPCIONAL, PARA SOLICITAR EN FASE DE PEDIDO

PER APPLICAZIONI INCLINATE CONSULTARE IL NOSTRO UFFICIO TECNICO.
FOR THE POSSIBLE INCLINED APPLICATIONS CONSULT OUR TECHNICAL DEPARTMENT.
FÜR GENEIGTE ANWENDUNGEN SETZEN SIE SICH BITTE MIT DEM TECHNISCHEN BÜRO IN VERBINDUNG.
PARA APLICACIONES INCLINADAS CONSULTAR CON EL DEPARTAMENTO TÉCNICO.

ESEMPIO D'ORDINE RICAMBIO - SPARE PART ORDER EXAMPLE
BESTELLBEISPIEL EINZELTEILE - EJEMPLO DE PEDIDO DE RECAMBIOS

ML 170	+10°	002
MODELLO - MODEL	INCLINAZIONE - SLOPE	POSIZIONE - POSITION
MODELL - MODELO	NEIGUNG - INCLINACIÓN	POSITION - POSICIÓN

CAMMA M/ML

Ed. 03 - 06/2012 - Patent pending



M

ESEMPIO D'ORDINE - ORDER EXAMPLE
BESTELLBEISPIEL - EJEMPLO DE PEDIDO

M 170 **+10°**
MODELLO - MODEL INCLINAZIONE - SLOPE
MODELL - MODELO NEIGUNG - INCLINACIÓN

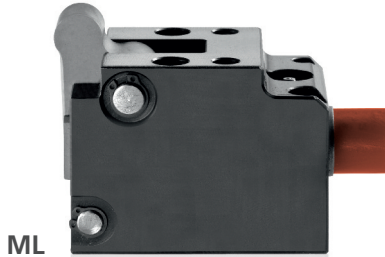
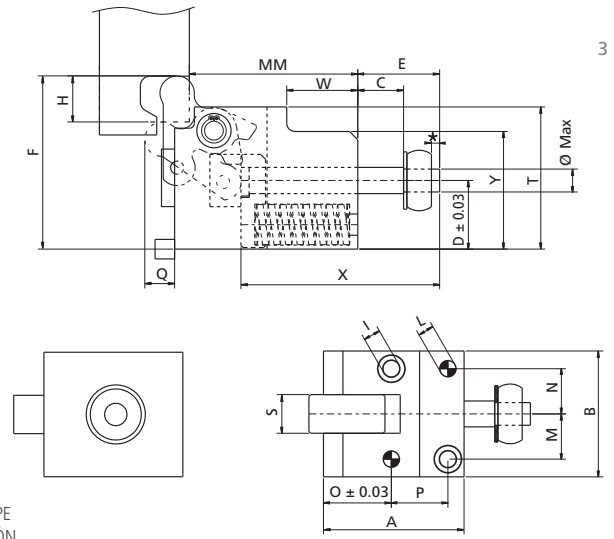

ML

ESEMPIO D'ORDINE - ORDER EXAMPLE
BESTELLBEISPIEL - EJEMPLO DE PEDIDO

ML 170 **+10°**
MODELLO - MODEL INCLINAZIONE - SLOPE
MODELL - MODELO NEIGUNG - INCLINACIÓN

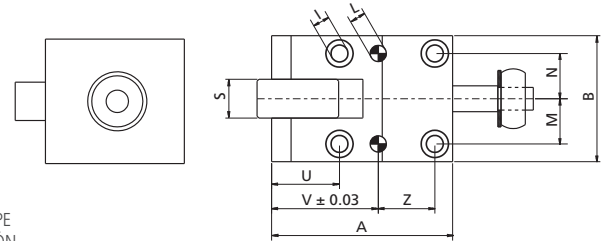

DISEGNO DEL MONTAGGIO / MOUNTING DESIGN
MONTAGEZEICHNUNG / DISEÑO DE MONTAJE

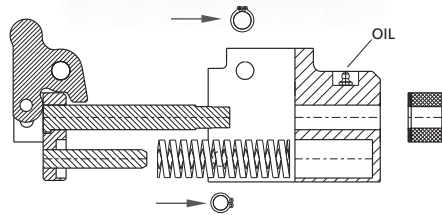

⚠ Si prega di consultare il nostro manuale di uso e manutenzione!
Please consult our Instruction Manual!
Bitte beachten Sie unsere Wartungsanweisung!
Por favor, consulte nuestro manual de instrucciones!

ESEMPI DI APPLICAZIONI SPECIALI / EXAMPLES OF SPECIAL APPLICATIONS
BEISPIELE FÜR SPEZIELLE ANWENDUNGEN / EJEMPLOS DE APLICACIONES ESPECIALES

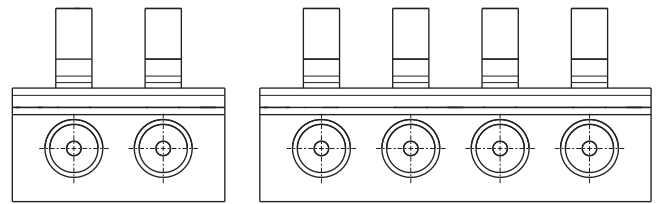

PUNZONE ISO 8020 / PUNCH ISO 8020 / LOCHSTEMPEL ISO 8020 / PUNZÓN ISO 8020

MODELLO - MODEL - MODELL - MODELO	X	G	Ø MAX
M170	64.5	8	6
ML170	89.5	8	6
M210	85.5	13	11
ML210	107.5	13	11
M320	96.5	16	14
ML320	121.5	16	14

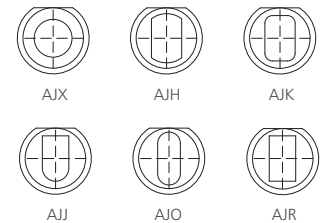
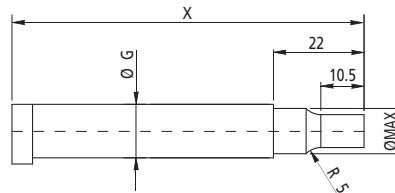

* MAX 30% DELLA LUNGHEZZA LIBERA (ASSETTAMENTO 5%) / MAX 30% OF THE FREE LENGTH (ADJUSTMENT 5%) / MAX. 30% DER FREIEN LÄNGE (SENKUNG 5%) / MAX 30% DE LA LONGITUD LIBRE (AJUSTE 5%)
DATI TECNICI MODELLO ESTRAZIONE MAX (daN) / TECHNICAL DATA OF THE MAX EXTRACTION MODEL (daN) / TECHNISCHE DATEN DES MODELLS MIT MAXIMALER RÜCKZUGSKRAFT (daN) / DATOS TÉCNICOS MODELO EXTRACCIÓN MAX (daN)

MODELLO e forza iniziale di estrazione in daN / MODEL - MODELL - MODELO	A	B	C	D	E	F	H	I	L ^{+0.02/0}	M	N	O	P	Q	R	S	T	U	V	Z	Y	W	X	MM	ØMAX	Sforzo max trancio daN / Cutting max force daN / Maximale Schnittkraft daN / Max fuerza de corte daN	
170	M	51	51	9,5	22	31,5	59	9,5	Ø 6,5	Ø 6	18,5	18,5	26	18	11	5	15	47	-	-	-	39	18	64,5	47	6	1000
	ML	76	51	19	22	41	59	19	Ø 6,5	Ø 6	18,5	18,5	-	-	10,7	5	15	47	26	50	18	39	31	89,5	72	6	1000
210	M	76	68	16	36	38	91	16	Ø 8,5	Ø 8	25	25	38	30	14,5	10	22	75	-	-	-	63	24	85,5	67	11	3000
	ML	98	68	25	36	47	91	25	Ø 8,5	Ø 8	25	25	-	-	14,0	10	22	75	38	59	30	63	33	107,5	92	11	3000
320	M	87	78	19	42	41	106	19	Ø 10,5	Ø 10	28	28	42	35	18,5	13,5	24	87	-	-	-	72	27	96,5	79,5	14	5000
	ML	112	78	28	42	50	106	28	Ø 10,5	Ø 10	28	28	-	-	18,5	13,5	24	87	42	66	35	72	43	121,5	104,5	14	5000



www.newstark.it

La Newstark si riserva di modificare il presente catalogo senza preavvisi.
Newstark reserves the right to make changes to the catalogue without any prior notice.
Newstark behält sich auch ohne Vorankündigung Änderungen am vorliegenden Katalog vor.
Newstark se reserva el derecho a realizar cambios en el catálogo sin previo aviso.

