



Cam Units CRX  
Schieber CRX  
Unità a Camme CRX



**OMCR**<sup>®</sup>  
STANDARD DIE COMPONENTS

2018.00



OMCR CODE	Work Angle	Slider Width (mm)	Work Area W x H (mm)	Max Work Force 10 <sup>6</sup> cycles (kN)	Extraction Force (kN)
	$\beta$			F <sub>s</sub>	E <sub>F</sub>
CRX01	-15°÷50°	78	78x63	45	2,5÷3,4
CRX03	-15°÷50°	98	98x63	76	3,4÷3,6
CRX05	-15°÷50°	118	118x74	142	6,36÷6,46
CRX15	-15°÷50°	170	170x94	166	6,45÷6,61
CRX20	-15°÷50°	240	240x110	258	9,29÷9,38

**ROLLER CAM DRIVER - TREIBER FÜR ROLLENSCHIEBER - CUNEO PER CAMME A RULLO**

OMCR CODE	Roller Cam Model	Work Angle $\beta$
DCRX0100	CRX01	-15°÷50° (5° steps)
DCRX0305	CRX03 - CRX05	-15°÷50° (5° steps)
DCRX1520	CRX15 - CRX20	-15°÷50° (5° steps)

**100% SAFETY WITH POSITIVE RETURN - 100 % SICHERHEIT MIT DER ZWANGSRÜCKHOLUNG  
100% SICURA CON IL GANCIO DI RITORNO**

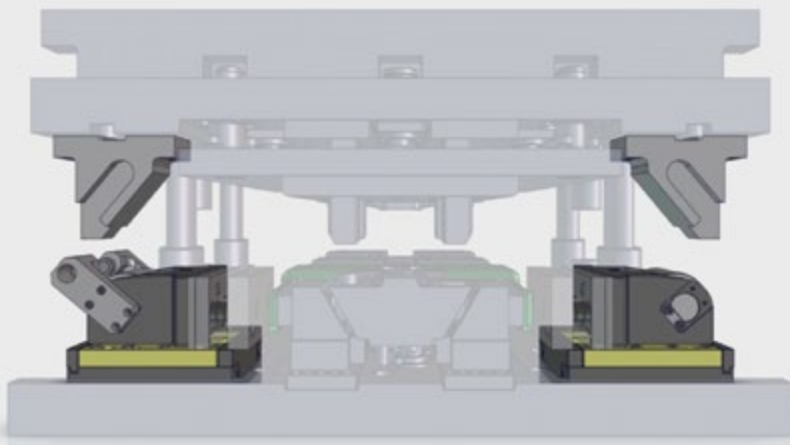

Cam Units CRX

CRX: how does it work?  
CRX: wie funktioniert es?  
CRX: come funziona?



ROLLER CAM UNIT - ROLLENSCHIEBER - CAMMA A RULLO

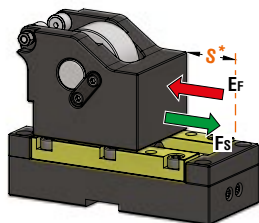

OMCR CODE	Stroke (mm)	Max Work Force (kN)	Extraction Force (kN)
	S*	F <sub>s</sub>	E <sub>f</sub>
CRX01.030	30	45	2,5
CRX01.050	50	45	3,4

\* Do not exceed the maximum stroke  
Den maximalen Hub nicht überschreiten  
Non superare la corsa massima



P.605

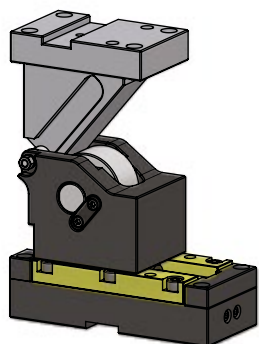

With Driver - **OPTION DRIVER**

OPTION DRIVER	Work angle (β)
H15	-15°
H10	-10°
H05	-5°
000	0
L05	5°
L10	10°
L15	15°
L20	20°
L25	25°
L30	30°
L35	35°
L40	40°
L45	45°
L50	50°

STOCK	ORDER EXAMPLE	Art.	Stroke = 30	OPTION DRIVER
		CRX01	030	H05

OMCR CODE	Stroke (mm)	Overall Dimensions (mm)		
	S*	A	B	C
CRX01.030	30	45	142	162
CRX01.050	50	65	162	182



ROLLER CAM UNIT - ROLLENSCHIEBER - CAMMA A RULLO

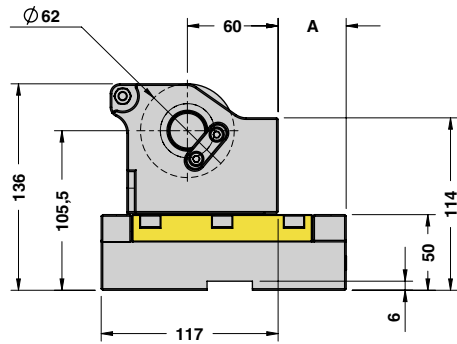
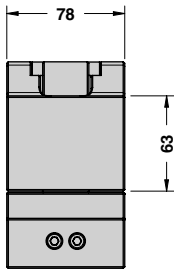
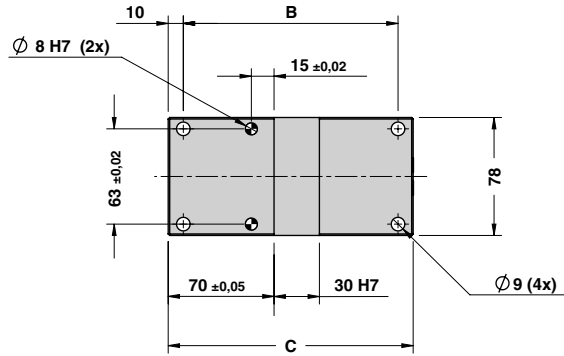



ROLLER CAM UNIT - ROLLENSCHIEBER - CAMMA A RULLO

WORK ANGLE ( $\beta$ ) FROM  $-5^\circ$  TO  $-15^\circ$

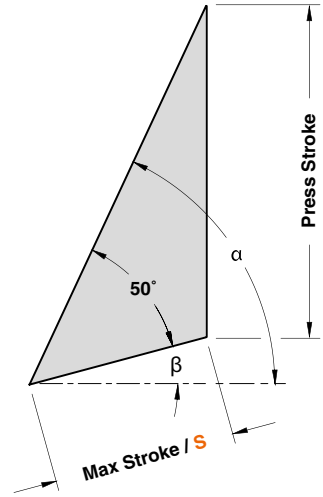
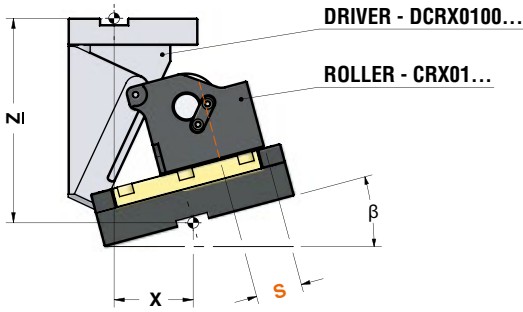

WORK ANGLE ( $\beta$ )= $0^\circ$

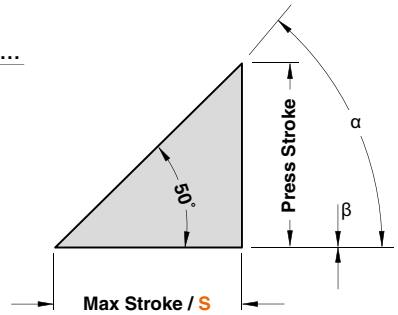
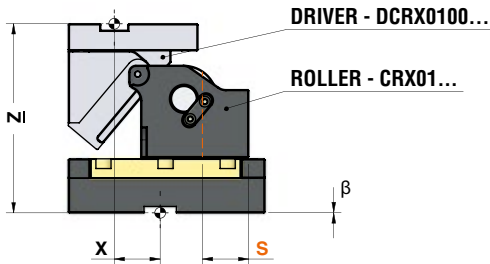

WORK ANGLE ( $\beta$ ) FROM  $5^\circ$  TO  $50^\circ$

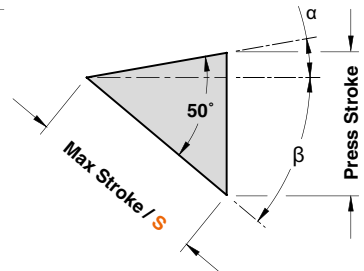
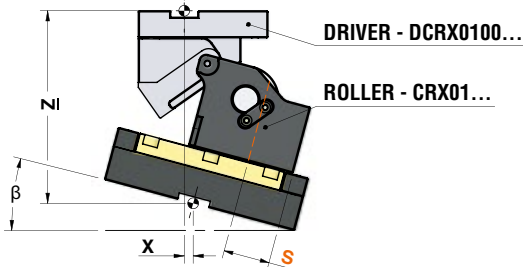



## ROLLER CAM UNIT - ROLLENSCHIEBER - CAMMA A RULLO

\*For more info see page 850 / Weitere Informationen finden Sie auf der Seite 850 / Per maggiori informazioni consultare la pagina 850

ROLLER CAM CODE	Work Angle $\beta$	$\alpha$	Max Stroke S (mm)	Press Stroke (mm)	*CAM DRIVER CODE	X (mm)	Z (mm)
CRX01.030	-15°	65°	30	54,4	DCRX0100.30.H15	73,20	175,60
	-10°	60°	30	46,0	DCRX0100.30.H10	63,49	174,00
	-5°	55°	30	40,1	DCRX0100.30.H05	53,23	169,90
	0°	50°	30	35,8	DCRX0100.30.000	42,50	175,00
	5°	45°	30	32,5	DCRX0100.30.L05	31,37	172,50
	10°	40°	30	30,0	DCRX0100.30.L10	19,93	175,00
	15°	35°	30	28,1	DCRX0100.30.L15	8,27	176,94
	20°	30°	30	26,5	DCRX0100.30.L20	-3,52	178,46
	25°	25°	30	25,4	DCRX0100.30.L25	-15,36	174,64
	30°	20°	30	24,5	DCRX0100.30.L30	-27,15	173,54
	35°	15°	30	23,8	DCRX0100.30.L35	-38,80	171,21
	40°	10°	30	23,3	DCRX0100.30.L40	-50,23	166,66
45°	5°	30	23,1	DCRX0100.30.L45	-61,35	161,93	
50°	0°	30	23,0	DCRX0100.30.L50	-72,07	157,02	
CRX01.050	-15°	65°	50	90,6	DCRX0100.50.H15	73,20	189,37
	-10°	60°	50	76,6	DCRX0100.50.H10	63,49	183,40
	-5°	55°	50	66,8	DCRX0100.50.H05	53,23	188,22
	0°	50°	50	59,6	DCRX0100.50.000	42,50	175,00
	5°	45°	50	54,2	DCRX0100.50.L05	31,37	179,83
	10°	40°	50	50,0	DCRX0100.50.L10	19,93	175,00
	15°	35°	50	46,8	DCRX0100.50.L15	8,27	178,24
	20°	30°	50	44,2	DCRX0100.50.L20	-3,52	175,77
	25°	25°	50	42,3	DCRX0100.50.L25	-15,36	172,74
	30°	20°	50	40,8	DCRX0100.50.L30	-27,15	169,24
	35°	15°	50	39,7	DCRX0100.50.L35	-38,80	170,35
	40°	10°	50	38,9	DCRX0100.50.L40	-50,23	161,11
45°	5°	50	38,4	DCRX0100.50.L45	-61,35	156,55	
50°	0°	50	38,3	DCRX0100.50.L50	-72,07	151,70	



ROLLER CAM UNIT - ROLLENSCHIEBER - CAMMA A RULLO

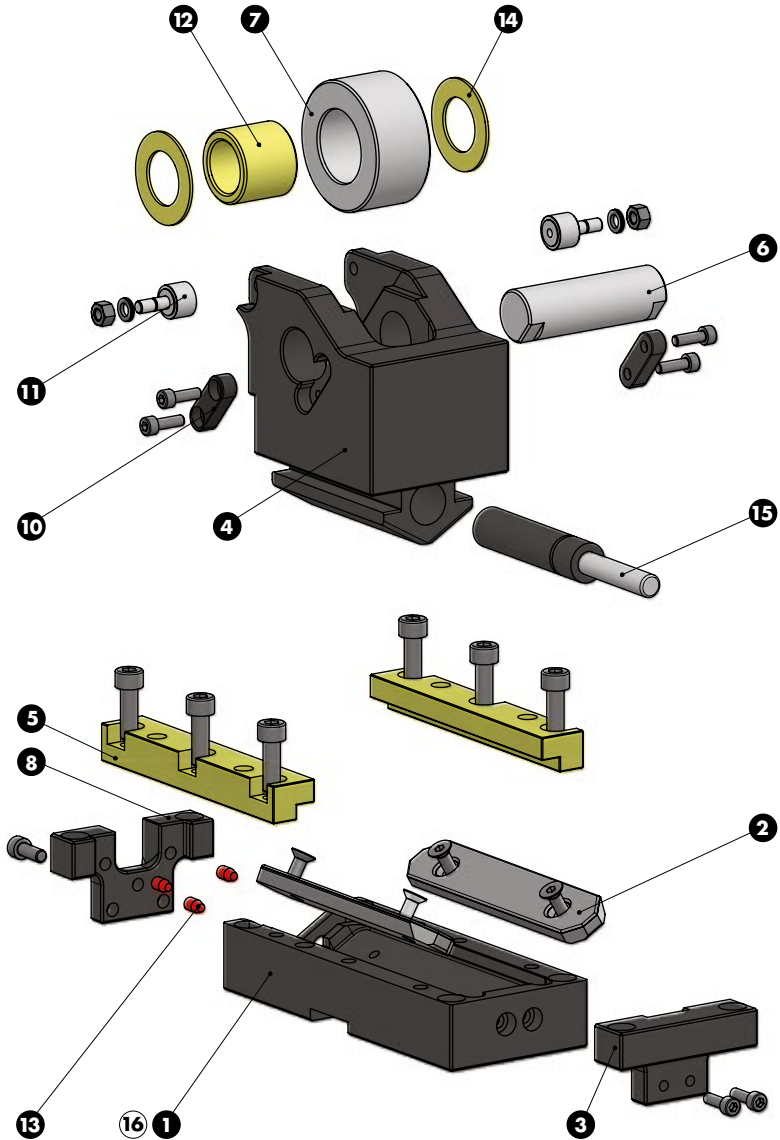



## ROLLER CAM UNIT - ROLLENSCHIEBER - CAMMA A RULLO

## SLIDER STRUCTURE AND CLEARANCES

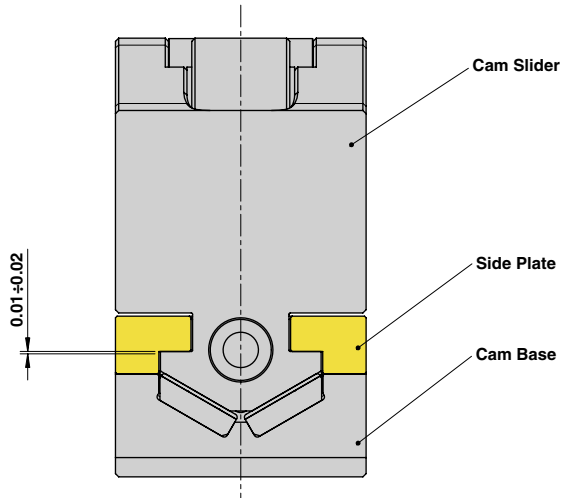

## PART LIST

Particular number	Description	Material	Quantity
1	Cam Base	CK45	1
2	Wear Plate	St42 + Syntered layer	2
3	Spring Stopper Plate	CK45	1
4	Cam Slider	CK45	1
5	Side Plate	CuZn25Al5 + Graphite - HB > 190	2
6	Pin	16NiCrMo4	1
7	Roller	100Cr6	1
8	Stopper Plate	CK45	2
10	Key	CK45	2
11	Roller KRV16PPA	CK45	2
12	Self-Lubricating Bush	CuZn25Al5 + Graphite - HB > 190	1
13	Elastomer Cap	Elastomer 92SH	3
14	Washer PCMW 264401.5M	-	2
15	Gas Spring	-	1
16	Cam Base Fixing Screws M8x30 DIN 912	-	4





ROLLER CAM UNIT - ROLLENSCHIEBER - CAMMA A RULLO

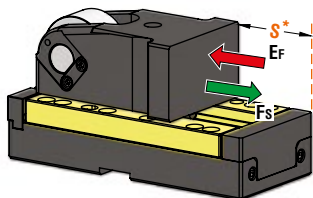

Without Positive Return - **OPTION K**

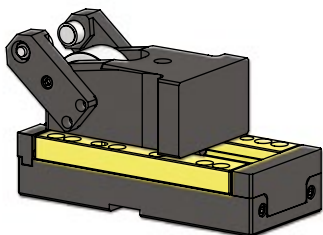

With Positive Return - **OPTION P**

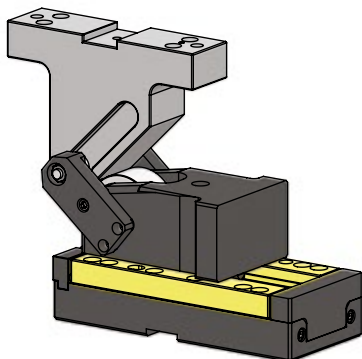

With Driver - **OPTION DRIVER**

OMCR CODE	Stroke (mm)	Max Work Force (kN)	Extraction Force (kN)
			EF
	S*	F <sub>s</sub>	Gas Spring
CRX03.050	50	76	3,4
CRX03.080	80	76	3,4
CRX03.100	100	76	3,6

\* Do not exceed the maximum stroke  
Den maximalen Hub nicht überschreiten  
Non superare la corsa massima



P.605

OPTION DRIVER	Work angle (β)
H15	-15°
H10	-10°
H05	-5°
000	0
L05	5°
L10	10°
L15	15°
L20	20°
L25	25°
L30	30°
L35	35°
L40	40°
L45	45°
L50	50°

STOCK



Art.	Stroke = 80	OPTION K-P	OPTION DRIVER
CRX03	080	K	H05

OMCR CODE	Stroke (mm)	Overall Dimensions (mm)				
	S*	A	B	C	D	E
CRX03.050	50	42	116	56	200	212
CRX03.080	80	72	146	86	230	242
CRX03.100	100	102	166	106	260	272



ROLLER CAM UNIT - ROLLENSCHIEBER - CAMMA A RULLO

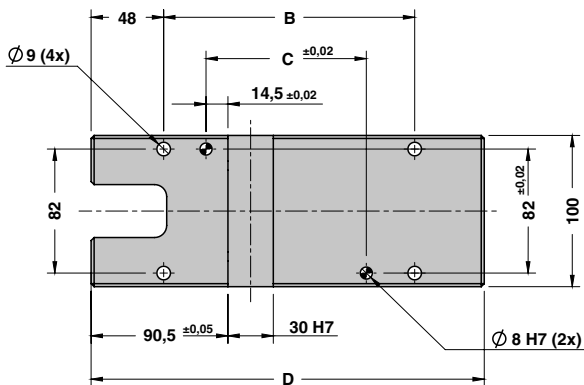

OPTION K

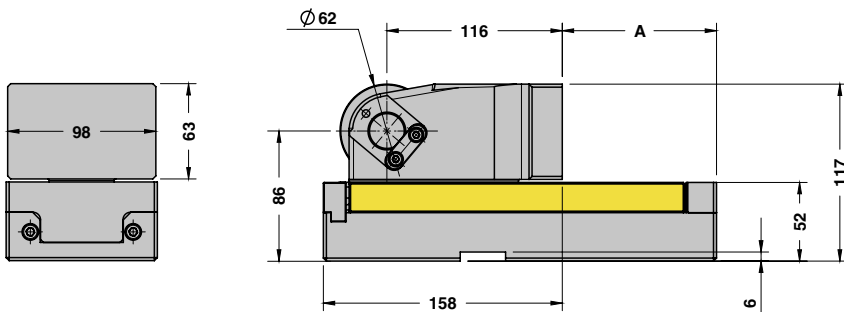

OPTION P

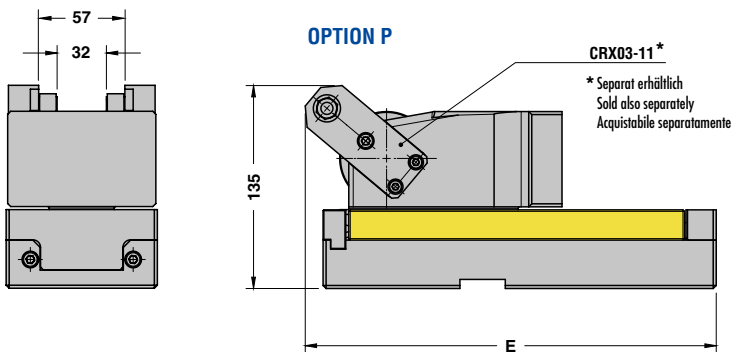

Cam Units CRX



ROLLER CAM UNIT - ROLLENSCHIEBER - CAMMA A RULLO

WORK ANGLE ( $\beta$ ) FROM  $-5^\circ$  TO  $-15^\circ$

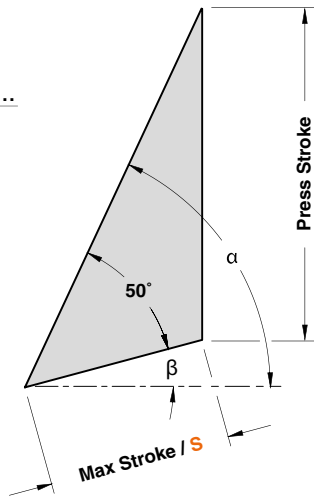
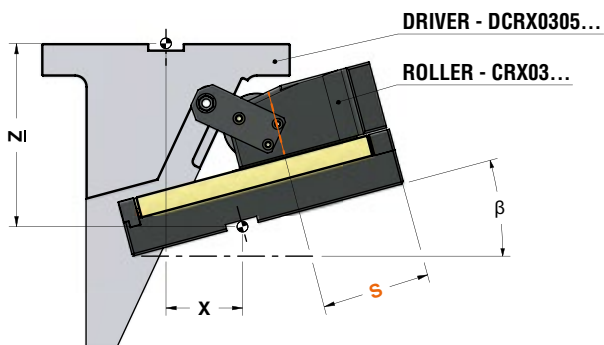

WORK ANGLE ( $\beta$ ) =  $0^\circ$

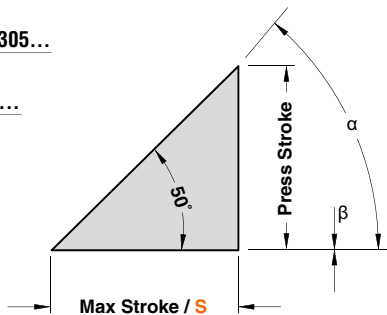
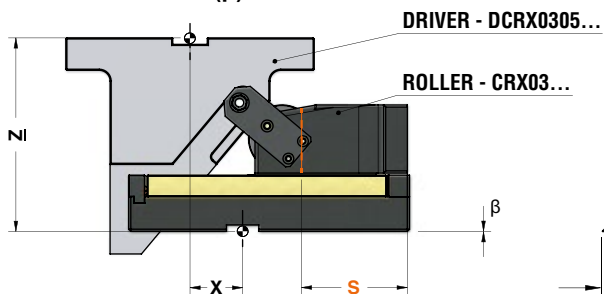

WORK ANGLE ( $\beta$ ) FROM  $5^\circ$  TO  $50^\circ$

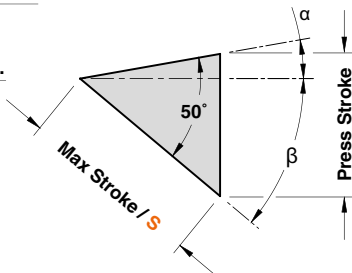
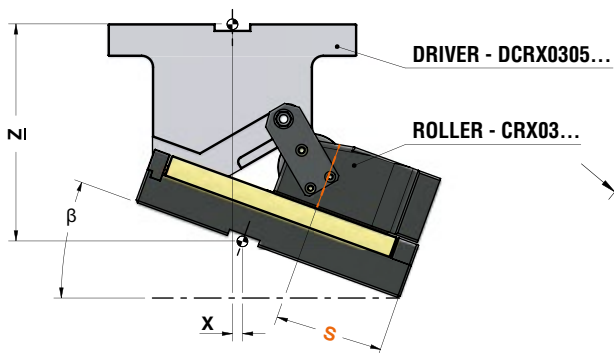



## ROLLER CAM UNIT - ROLLENSCHIEBER - CAMMA A RULLO

\*For more info see page 856 / Weitere Informationen finden Sie auf der Seite 856 / Per maggiori informazioni consultare la pagina 856

ROLLER CAM CODE	Work Angle $\beta$	$\alpha$	Max Stroke S (mm)	Press Stroke (mm)	*CAM DRIVER CODE	X (mm)	Z (mm)
CRX03.050	-15°	65°	50	90,63	DCRX0305.50.H15	95,92	165,04
	-10°	60°	50	76,60	DCRX0305.50.H10	89,32	168,90
	-5°	55°	50	66,78	DCRX0305.50.H05	81,88	177,95
	0°	50°	50	59,59	DCRX0305.50.000	73,68	183,68
	5°	45°	50	54,17	DCRX0305.50.L05	64,75	186,89
	10°	40°	50	50,00	DCRX0305.50.L10	55,19	193,04
	15°	35°	50	46,76	DCRX0305.50.L15	45,05	197,40
	20°	30°	50	44,23	DCRX0305.50.L20	34,42	200,15
	25°	25°	50	42,26	DCRX0305.50.L25	23,37	196,39
	30°	20°	50	40,76	DCRX0305.50.L30	11,99	191,18
	35°	15°	50	39,65	DCRX0305.50.L35	0,37	189,57
	40°	10°	50	38,89	DCRX0305.50.L40	-11,40	186,60
45°	5°	50	38,45	DCRX0305.50.L45	-23,25	182,27	
50°	0°	50	38,30	DCRX0305.50.L50	-35,06	176,62	
CRX03.080	-15°	65°	80	145,01	DCRX0305.80.H15	70,92	205,66
	-10°	60°	80	122,57	DCRX0305.80.H10	64,32	207,94
	-5°	55°	80	106,84	DCRX0305.80.H05	56,88	202,88
	0°	50°	80	95,34	DCRX0305.80.000	48,68	202,93
	5°	45°	80	86,67	DCRX0305.80.L05	39,75	199,39
	10°	40°	80	80,00	DCRX0305.80.L10	30,19	208,04
	15°	35°	80	74,81	DCRX0305.80.L15	20,05	214,35
	20°	30°	80	70,76	DCRX0305.80.L20	9,42	218,61
	25°	25°	80	67,62	DCRX0305.80.L25	-1,63	216,03
	30°	20°	80	65,22	DCRX0305.80.L30	-13,01	211,20
	35°	15°	80	63,45	DCRX0305.80.L35	-24,63	200,78
	40°	10°	80	62,23	DCRX0305.80.L40	-36,40	188,26
45°	5°	80	61,52	DCRX0305.80.L45	-48,25	179,21	
50°	0°	80	61,28	DCRX0305.80.L50	-60,06	168,64	
CRX03.100	-15°	65°	100	181,26	DCRX0305.80.H15	70,92	169,41
	-10°	60°	100	153,21	DCRX0305.80.H10	64,32	177,30
	-5°	55°	100	133,56	DCRX0305.80.H05	56,88	176,17
	0°	50°	100	119,18	DCRX0305.80.000	48,68	179,09
	5°	45°	100	108,34	DCRX0305.80.L05	39,75	177,72
	10°	40°	100	100,00	DCRX0305.80.L10	30,19	188,04
	15°	35°	100	93,52	DCRX0305.80.L15	20,05	195,65
	20°	30°	100	88,46	DCRX0305.80.L20	9,42	200,92
	25°	25°	100	84,52	DCRX0305.80.L25	-1,63	199,12
	30°	20°	100	81,52	DCRX0305.80.L30	-13,01	195,42
	35°	15°	100	79,31	DCRX0305.80.L35	-24,63	184,92
	40°	10°	100	77,79	DCRX0305.80.L40	-36,40	172,70
45°	5°	100	76,90	DCRX0305.80.L45	-48,25	163,83	
50°	0°	100	76,60	DCRX0305.80.L50	-60,06	153,32	



ROLLER CAM UNIT - ROLLENSCHIEBER - CAMMA A RULLO

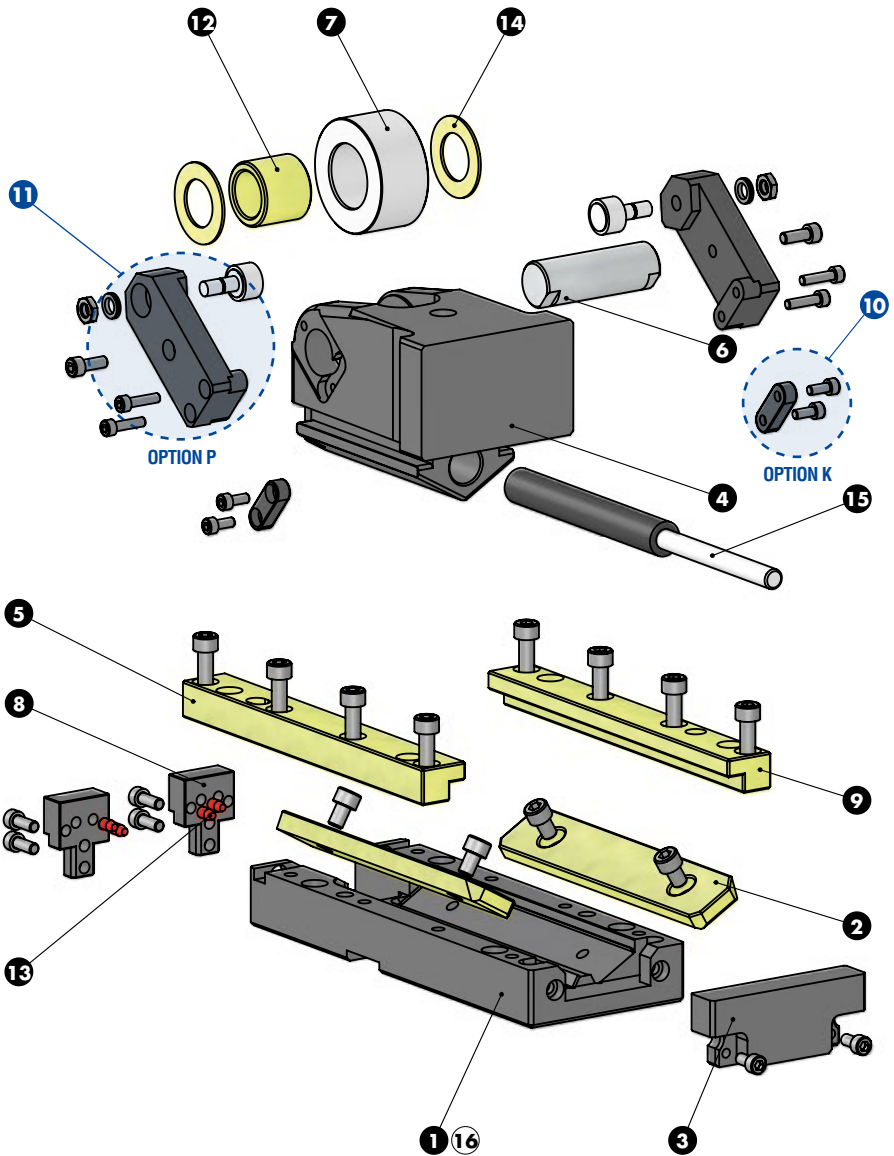

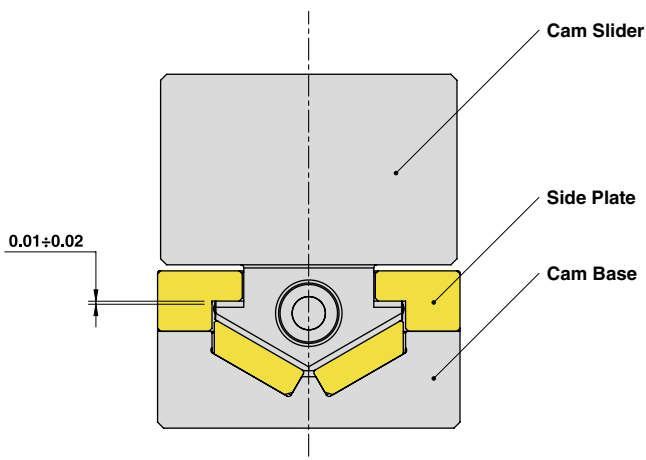

**ROLLER CAM UNIT - ROLLENSCHIEBER - CAMMA A RULLO**
**SLIDER STRUCTURE AND CLEARANCES**

**PART LIST**

Particular number	Description	Material	Quantity
1	Cam Base	CK45	1
2	Wear Plate	CuZn25Al5 + Graphite - HB > 190	2
3	Spring Stopper Plate	CK45	1
4	Cam Slider	CK45	1
5	Side Plate L	CuZn25Al5 + Graphite - HB > 190	1
6	Pin	16NiCrMo4	1
7	Roller	100Cr6	1
8	Stopper Plate	CK45	2
9	Side Plate R	CuZn25Al5 + Graphite - HB > 190	1
10	Key - <b>OPTION K</b>	CK45	2
11	Positive Return + Roller KRV19PPA - <b>OPTION P</b>	CK45	2
12	Self-Lubricating Bush	CuZn25Al5 + Graphite - HB > 190	1
13	Elastomer Cap	Elastomer 92SH	4
14	Washer PCMW 264401.5M	-	2
15	Gas Spring	-	1
16	Cam Base Fixing Screws M8x30 DIN 912	-	4

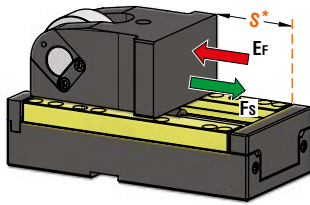

ROLLER CAM UNIT - ROLLENSCHIEBER - CAMMA A RULLO



Without Positive Return - **OPTION K**

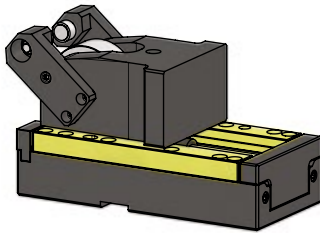

With Positive Return - **OPTION P**

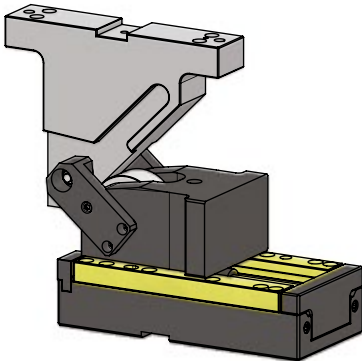

With Driver - **OPTION DRIVER**

OMCR CODE	Stroke (mm)	Max Work Force (kN)	Extraction Force (kN)
	S*		E <sub>f</sub>
CRX05.050	50	142	6,36
CRX05.080	80	142	6,43
CRX05.100	100	142	6,46

\* Do not exceed the maximum stroke  
Den maximalen Hub nicht überschreiten  
Non superare la corsa massima



P.605

OPTION DRIVER	Work angle (β)
H15	-15°
H10	-10°
H05	-5°
000	0
L05	5°
L10	10°
L15	15°
L20	20°
L25	25°
L30	30°
L35	35°
L40	40°
L45	45°
L50	50°

STOCK	ORDER EXAMPLE	Art.	Stroke = 80	OPTION K-P	OPTION DRIVER
		CRX05	080	K	H05

OMCR CODE	Stroke (mm)	Overall Dimensions (mm)				
	S*	A	B	C	D	E
CRX05.050	50	42	116	59	200	213
CRX05.080	80	72	146	89	230	243
CRX05.100	100	102	166	109	260	273



ROLLER CAM UNIT - ROLLENSCHIEBER - CAMMA A RULLO

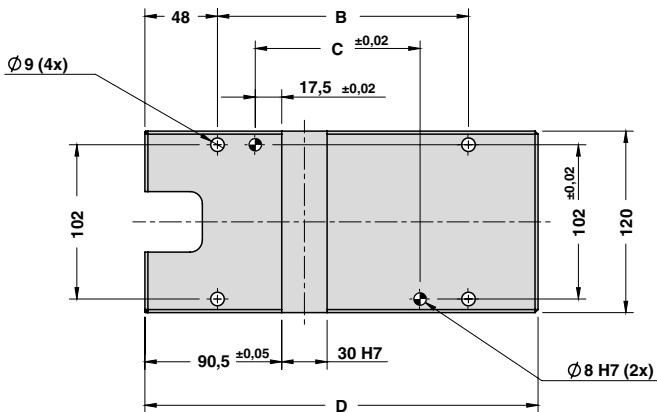

OPTION K

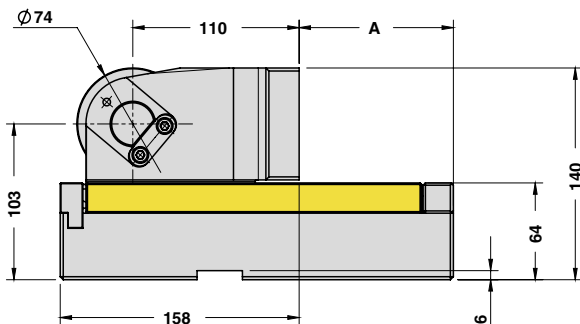
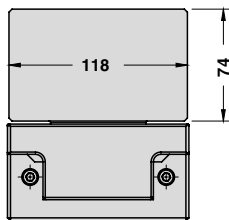

OPTION P

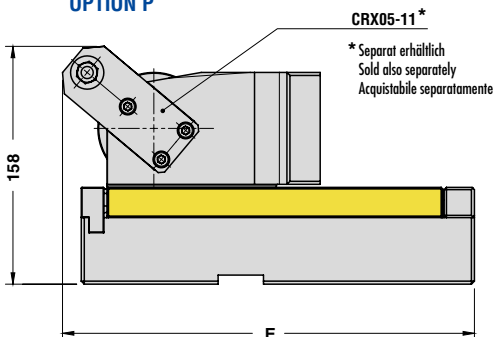
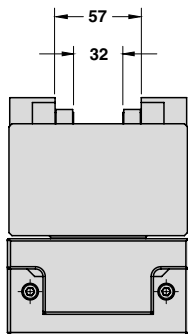





ROLLER CAM UNIT - ROLLENSCHIEBER - CAMMA A RULLO

WORK ANGLE ( $\beta$ ) FROM  $-5^\circ$  TO  $-15^\circ$

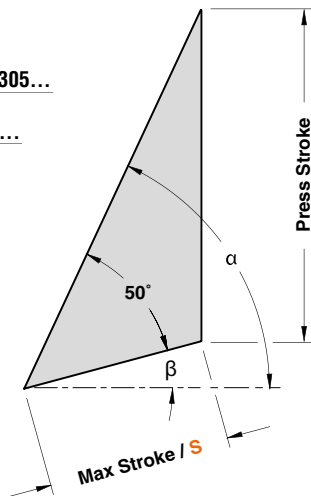
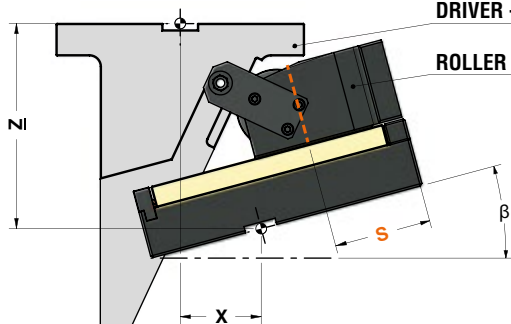

WORK ANGLE ( $\beta$ )= $0^\circ$

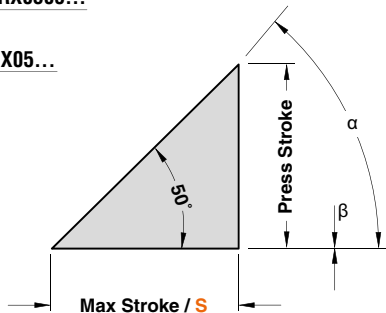
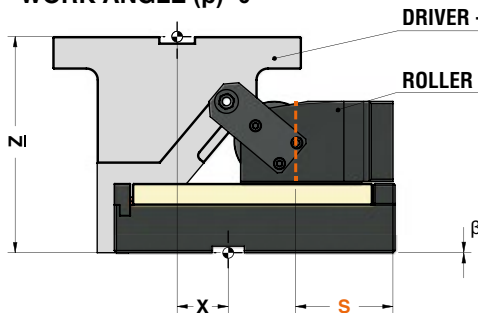

WORK ANGLE ( $\beta$ ) FROM  $5^\circ$  TO  $50^\circ$

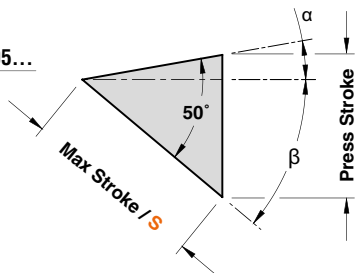
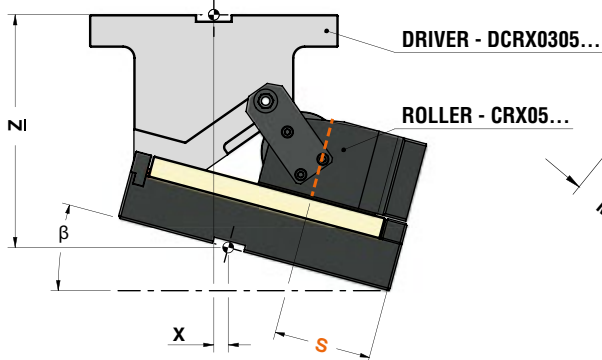



## ROLLER CAM UNIT - ROLLENSCHIEBER - CAMMA A RULLO

\*For more info see page 862 / Weitere Informationen finden Sie auf der Seite 862 / Per maggiori informazioni consultare la pagina 862

ROLLER CAM CODE	Work Angle $\beta$	$\alpha$	Max Stroke S (mm)	Press Stroke (mm)	*CAM DRIVER CODE	X (mm)	Z (mm)
CRX05.050	-15°	65°	50	90,63	DCRX0305.50.H15	99,96	185,55
	-10°	60°	50	76,60	DCRX0305.50.H10	91,56	189,69
	-5°	55°	50	66,78	DCRX0305.50.H05	82,30	198,85
	0°	50°	50	59,59	DCRX0305.50.000	72,27	204,54
	5°	45°	50	54,17	DCRX0305.50.L05	61,54	207,54
	10°	40°	50	50,00	DCRX0305.50.L10	50,18	213,34
	15°	35°	50	46,76	DCRX0305.50.L15	38,30	217,19
	20°	30°	50	44,23	DCRX0305.50.L20	25,96	219,27
	25°	25°	50	42,26	DCRX0305.50.L25	13,28	214,70
	30°	20°	50	40,76	DCRX0305.50.L30	0,35	208,54
	35°	15°	50	39,65	DCRX0305.50.L35	-12,74	205,85
	40°	10°	50	38,89	DCRX0305.50.L40	-25,89	201,67
45°	5°	50	38,45	DCRX0305.50.L45	-38,99	196,03	
50°	0°	50	38,30	DCRX0305.50.L50	-51,94	188,95	
CRX05.080	-15°	65°	80	145,01	DCRX0305.80.H15	74,96	226,17
	-10°	60°	80	122,57	DCRX0305.80.H10	66,56	228,72
	-5°	55°	80	106,84	DCRX0305.80.H05	57,30	223,78
	0°	50°	80	95,34	DCRX0305.80.000	47,27	223,78
	5°	45°	80	86,67	DCRX0305.80.L05	36,54	220,04
	10°	40°	80	80,00	DCRX0305.80.L10	25,18	228,34
	15°	35°	80	74,81	DCRX0305.80.L15	13,30	234,13
	20°	30°	80	70,76	DCRX0305.80.L20	0,96	237,73
	25°	25°	80	67,62	DCRX0305.80.L25	-11,72	234,34
	30°	20°	80	65,22	DCRX0305.80.L30	-24,65	229,08
	35°	15°	80	63,45	DCRX0305.80.L35	-37,74	217,06
	40°	10°	80	62,23	DCRX0305.80.L40	-50,89	203,34
45°	5°	80	61,52	DCRX0305.80.L45	-63,99	192,96	
50°	0°	80	61,28	DCRX0305.80.L50	-76,94	180,97	
CRX05.100	-15°	65°	100	181,26	DCRX0305.80.H15	74,96	189,92
	-10°	60°	100	153,21	DCRX0305.80.H10	66,56	198,08
	-5°	55°	100	133,56	DCRX0305.80.H05	57,30	197,07
	0°	50°	100	119,18	DCRX0305.80.000	47,27	199,95
	5°	45°	100	108,34	DCRX0305.80.L05	36,54	199,09
	10°	40°	100	100,00	DCRX0305.80.L10	25,18	208,34
	15°	35°	100	93,52	DCRX0305.80.L15	13,30	215,43
	20°	30°	100	88,46	DCRX0305.80.L20	0,96	220,04
	25°	25°	100	84,52	DCRX0305.80.L25	-11,72	217,43
	30°	20°	100	81,52	DCRX0305.80.L30	-24,65	212,78
	35°	15°	100	79,31	DCRX0305.80.L35	-37,74	201,20
	40°	10°	100	77,79	DCRX0305.80.L40	-50,89	187,78
45°	5°	100	76,90	DCRX0305.80.L45	-63,99	177,58	
50°	0°	100	76,60	DCRX0305.80.L50	-76,94	165,65	



ROLLER CAM UNIT - ROLLENSCHIEBER - CAMMA A RULLO

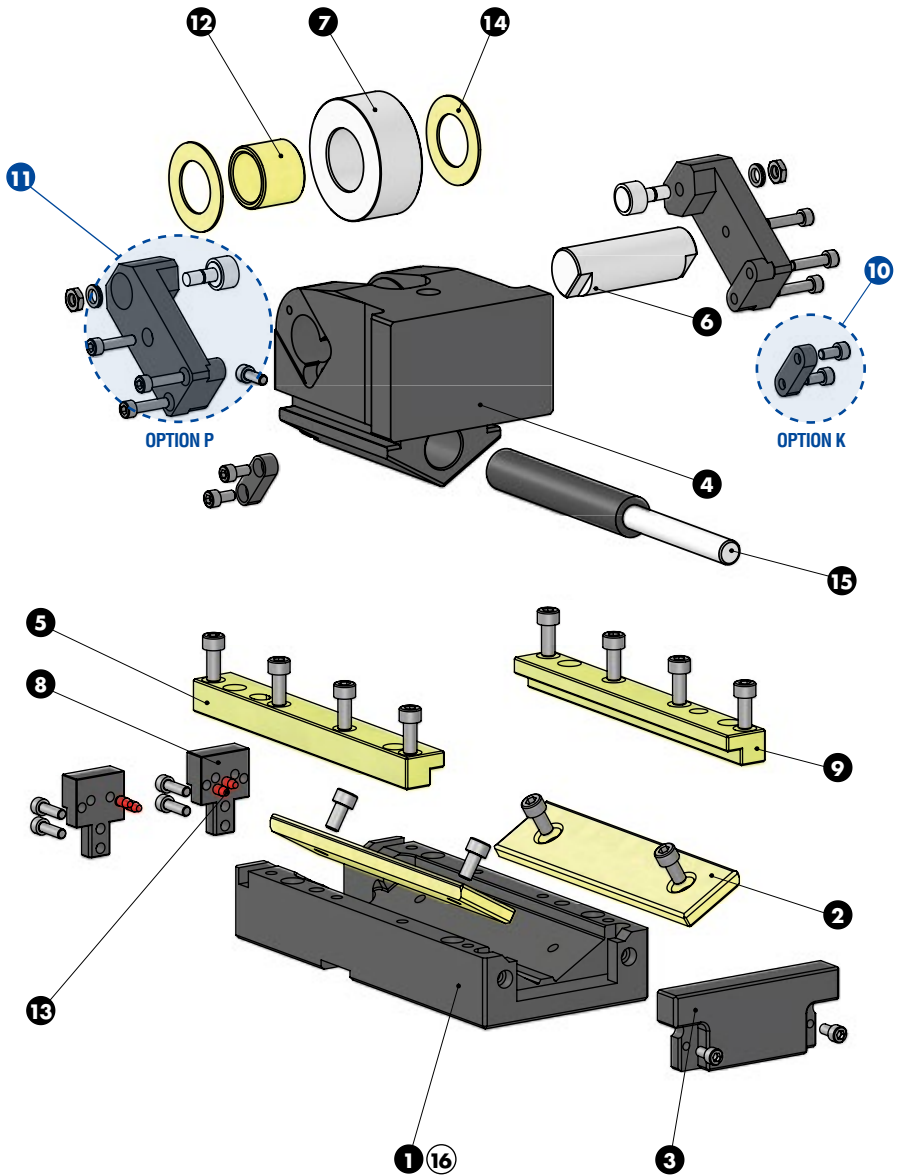



## ROLLER CAM UNIT - ROLLENSCHIEBER - CAMMA A RULLO

### SLIDER STRUCTURE AND CLEARANCES

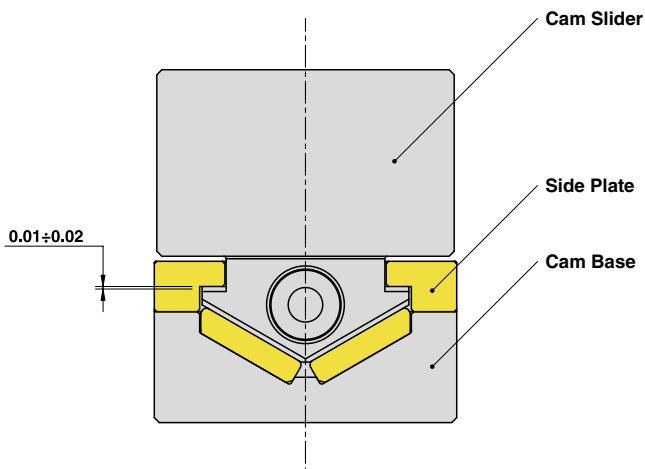

#### PART LIST

Particular number	Description	Material	Quantity
1	Cam Base	CK45	1
2	Wear Plate	CuZn25Al5 + Graphite - HB > 190	2
3	Spring Stopper Plate	CK45	1
4	Cam Slider	CK45	1
5	Side Plate L	CuZn25Al5 + Graphite - HB > 190	1
6	Pin	16NiCrMo4	1
7	Roller	100Cr6	1
8	Stopper Plate	CK45	2
9	Side Plate R	CuZn25Al5 + Graphite - HB > 190	1
10	Key - <b>OPTION K</b>	CK45	2
11	Positive Return + Roller KRV19PPA - <b>OPTION P</b>	CK45	2
12	Self-Lubricating Bush	CuZn25Al5 + Graphite - HB > 190	1
13	Elastomer Cap	Elastomer 92SH	4
14	Washer PCMW 325401.5M	-	2
15	Gas Spring	-	1
16	Cam Base Fixing Screws M8x30 DIN 912	-	4



ROLLER CAM UNIT - ROLLENSCHIEBER - CAMMA A RULLO

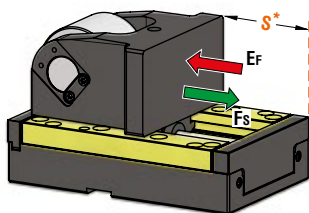

Without Positive Return - **OPTION K**

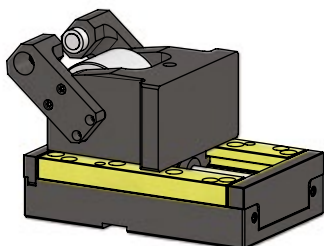

With Positive Return - **OPTION P**

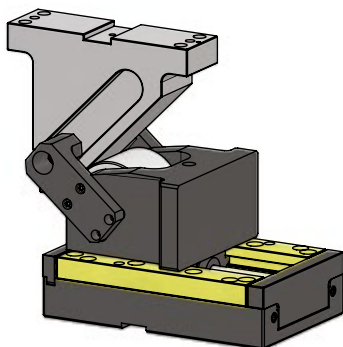

With Driver - **OPTION DRIVER**

OMCR CODE	Stroke (mm)	Max Work Force (kN)	Extraction Force (kN)
			Gas Spring
CRX15.050	50	166	6,45
CRX15.080	80	166	6,57
CRX15.100	100	166	6,61

\* Do not exceed the maximum stroke  
Den maximalen Hub nicht überschreiten  
Non superare la corsa massima



P.605

OPTION DRIVER	Work angle (°)
H15	-15°
H10	-10°
H05	-5°
000	0
L05	5°
L10	10°
L15	15°
L20	20°
L25	25°
L30	30°
L35	35°
L40	40°
L45	45°
L50	50°

STOCK	ORDER EXAMPLE	Art.	Stroke = 80	OPTION K-P	OPTION DRIVER
		CRX15	080	K	H05

OMCR CODE	Stroke (mm)	Overall Dimensions (mm)				
	S*	A	B	C	D	E
CRX15.050	50	55	123	47	220	243
CRX15.080	80	85	153	77	250	273
CRX15.100	100	105	173	97	270	293



ROLLER CAM UNIT - ROLLENSCHIEBER - CAMMA A RULLO

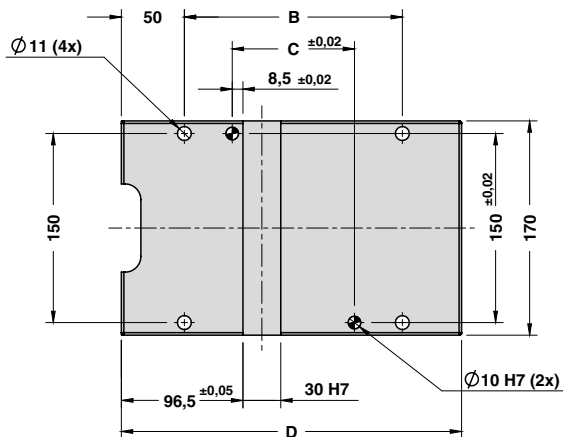

OPTION K

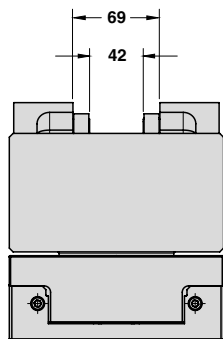
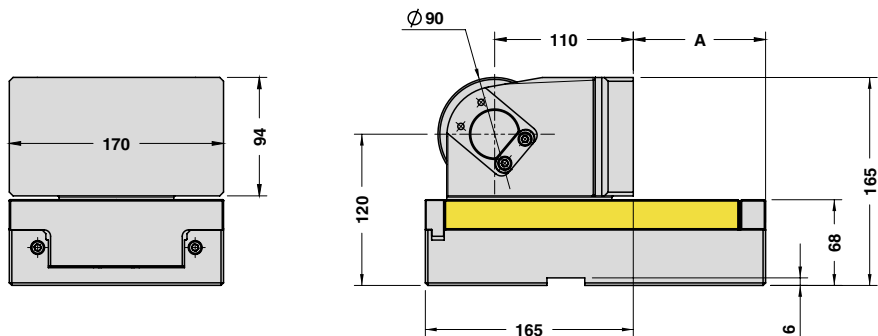

OPTION P

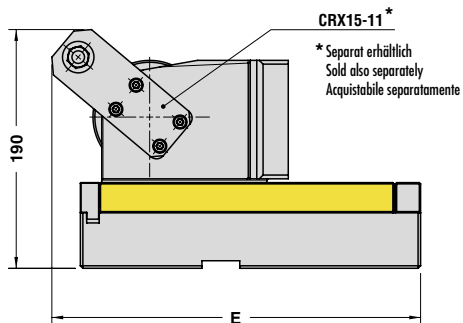



ROLLER CAM UNIT - ROLLENSCHIEBER - CAMMA A RULLO

WORK ANGLE ( $\beta$ ) FROM  $-5^\circ$  TO  $-15^\circ$

DRIVER - DCRX1520...

ROLLER - CRX15...

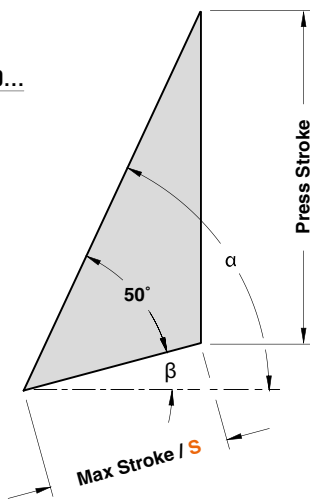
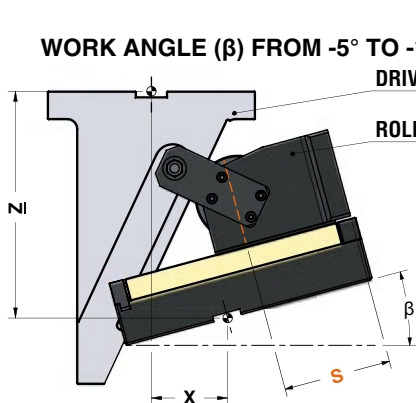

WORK ANGLE ( $\beta$ )=0°

DRIVER - DCRX1520...

ROLLER - CRX15...

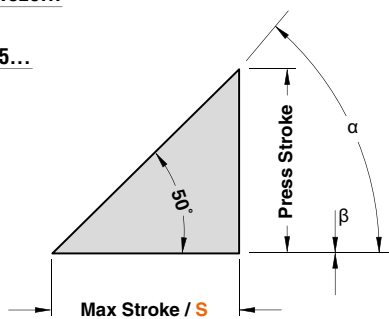
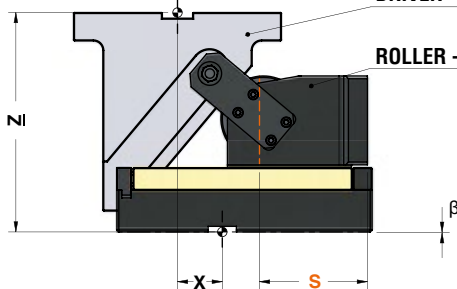

WORK ANGLE ( $\beta$ ) FROM  $5^\circ$  TO  $50^\circ$

DRIVER - DCRX1520...

ROLLER - CRX15...

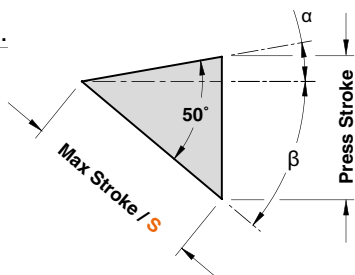
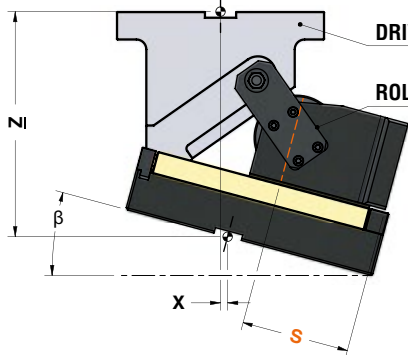



## ROLLER CAM UNIT - ROLLENSCHIEBER - CAMMA A RULLO

\*For more info see page 868 / Weitere Informationen finden Sie auf der Seite 868 / Per maggiori informazioni consultare la pagina 868

ROLLER CAM CODE	Work Angle $\beta$	$\alpha$	Max Stroke S (mm)	Press Stroke (mm)	*CAM DRIVER CODE	X (mm)	Z (mm)
CRX15.050	-15°	65°	50	90,63	DCRX1520.50.H15	105,64	220,61
	-10°	60°	50	76,60	DCRX1520.50.H10	95,45	220,60
	-5°	55°	50	66,78	DCRX1520.50.H05	84,34	220,46
	0°	50°	50	59,59	DCRX1520.50.000	72,39	226,67
	5°	45°	50	54,17	DCRX1520.50.L05	59,71	230,04
	10°	40°	50	50,00	DCRX1520.50.L10	46,38	236,03
	15°	35°	50	46,76	DCRX1520.50.L15	32,51	239,90
	20°	30°	50	44,23	DCRX1520.50.L20	18,21	241,83
	25°	25°	50	42,26	DCRX1520.50.L25	3,57	236,93
	30°	20°	50	40,76	DCRX1520.50.L30	-11,28	230,27
	35°	15°	50	39,65	DCRX1520.50.L35	-26,24	226,93
	40°	10°	50	38,89	DCRX1520.50.L40	-41,19	221,92
45°	5°	50	38,45	DCRX1520.50.L45	-56,01	215,31	
50°	0°	50	38,30	DCRX1520.50.L50	-95,60	222,11	
CRX15.080	-15°	65°	80	145,01	DCRX1520.80.H15	80,64	276,23
	-10°	60°	80	122,57	DCRX1520.80.H10	70,45	259,63
	-5°	55°	80	106,84	DCRX1520.80.H05	59,34	255,39
	0°	50°	80	95,34	DCRX1520.80.000	47,39	255,92
	5°	45°	80	86,67	DCRX1520.80.L05	34,71	247,54
	10°	40°	80	80,00	DCRX1520.80.L10	21,38	256,03
	15°	35°	80	74,81	DCRX1520.80.L15	7,51	256,84
	20°	30°	80	70,76	DCRX1520.80.L20	-6,78	260,29
	25°	25°	80	67,62	DCRX1520.80.L25	-21,42	251,57
	30°	20°	80	65,22	DCRX1520.80.L30	-36,28	250,82
	35°	15°	80	63,45	DCRX1520.80.L35	-51,24	233,13
	40°	10°	80	62,23	DCRX1520.80.L40	-66,19	223,59
45°	5°	80	61,52	DCRX1520.80.L45	-81,01	212,24	
50°	0°	80	61,28	DCRX1520.80.L50	-95,60	199,13	
CRX15.100	-15°	65°	100	181,26	DCRX1520.80.H15	80,64	239,98
	-10°	60°	100	153,21	DCRX1520.80.H10	70,45	228,99
	-5°	55°	100	133,56	DCRX1520.80.H05	59,34	228,68
	0°	50°	100	119,18	DCRX1520.80.000	47,39	232,08
	5°	45°	100	108,34	DCRX1520.80.L05	34,71	225,88
	10°	40°	100	100,00	DCRX1520.80.L10	21,38	236,03
	15°	35°	100	93,52	DCRX1520.80.L15	7,51	238,14
	20°	30°	100	88,46	DCRX1520.80.L20	-6,78	242,60
	25°	25°	100	84,52	DCRX1520.80.L25	-21,42	234,66
	30°	20°	100	81,52	DCRX1520.80.L30	-36,28	234,51
	35°	15°	100	79,31	DCRX1520.50.L35	-51,24	217,27
	40°	10°	100	77,79	DCRX1520.80.L40	-66,19	208,03
45°	5°	100	76,90	DCRX1520.80.L45	-81,01	196,86	
50°	0°	100	76,60	DCRX1520.80.L50	-95,60	183,81	





ROLLER CAM UNIT - ROLLENSCHIEBER - CAMMA A RULLO

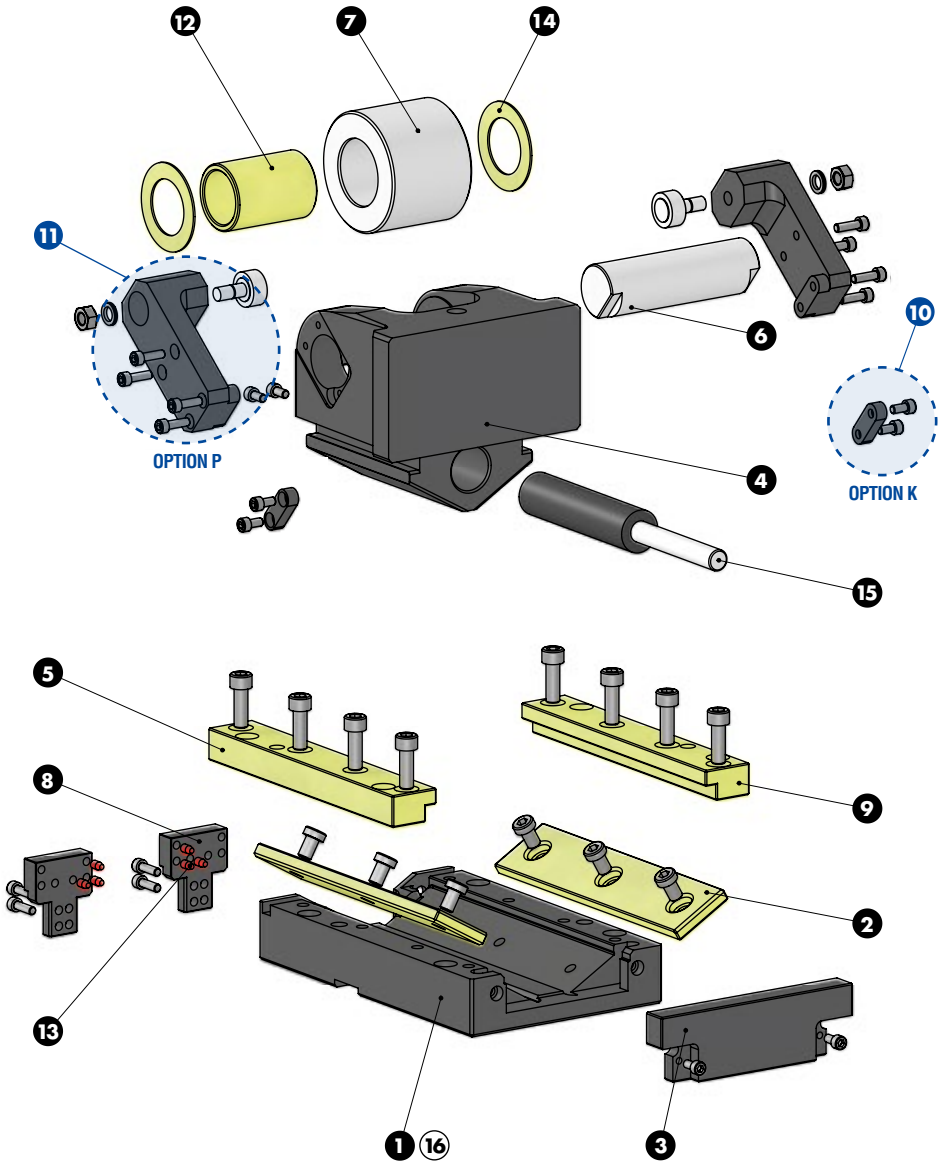

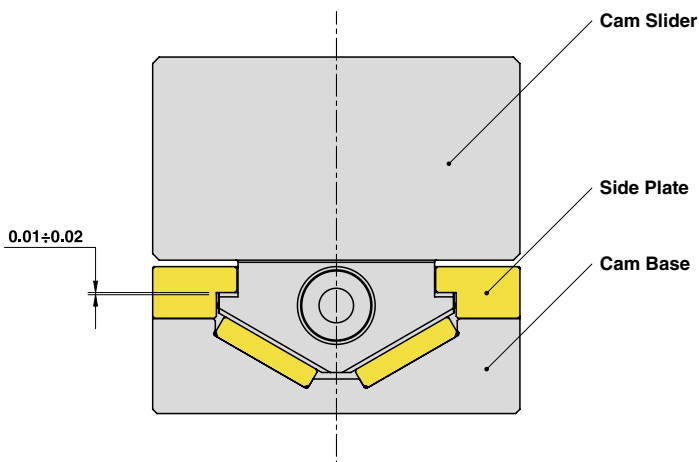

**ROLLER CAM UNIT - ROLLENSCHIEBER - CAMMA A RULLO**
**SLIDER STRUCTURE AND CLEARANCES**

**PART LIST**

Particular number	Description	Material	Quantity
1	Cam Base	CK45	1
2	Wear Plate	CuZn25Al5 + Graphite - HB > 190	2
3	Gas Spring Stopper Plate	CK45	1
4	Cam Slider	CK45	1
5	Side Plate L	CuZn25Al5 + Graphite - HB > 190	1
6	Pin	16NiCrMo4	1
7	Roller	100Cr6	1
8	Stopper Plate	CK45	2
9	Side Plate R	CuZn25Al5 + Graphite - HB > 190	1
10	Key - <b>OPTION K</b>	CK45	2
11	Positive Return + Roller KRV26PPA - <b>OPTION P</b>	CK45	2
12	Self-Lubricating Bush	CuZn25Al5 + Graphite - HB > 190	1
13	Elastomer Cap	Elastomer 92SH	6
14	Washer PCMW 426601.5M	-	2
15	Gas Spring	-	1
16	Cam Base Fixing Screws M10x35 DIN 912	-	4

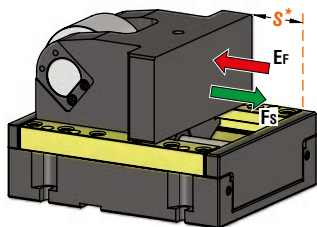

ROLLER CAM UNIT - ROLLENSCHIEBER - CAMMA A RULLO



Without Positive Return - **OPTION K**

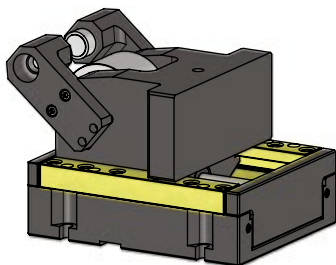

With Positive Return - **OPTION P**

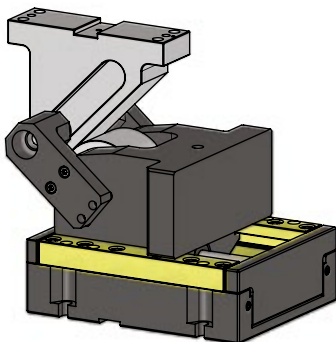

With Driver - **OPTION DRIVER**

OMCR CODE	Stroke (mm)	Max Work Force (kN)	Extraction Force (kN)
	S*	F <sub>s</sub>	E <sub>f</sub> Gas Spring
CRX20.050	50	258	9,29
CRX20.080	80	258	9,36
CRX20.100	100	258	9,38

\* Do not exceed the maximum stroke  
Den maximalen Hub nicht überschreiten  
Non superare la corsa massima



P.605

OPTION DRIVER	Work angle (β)
H15	-15°
H10	-10°
H05	-5°
000	0
L05	5°
L10	10°
L15	15°
L20	20°
L25	25°
L30	30°
L35	35°
L40	40°
L45	45°
L50	50°

STOCK	ORDER EXAMPLE	Art.	Stroke = 80	OPTION K-P	OPTION DRIVER
		CRX20	080	K	H05

OMCR CODE	Stroke (mm)	Overall Dimensions (mm)				
	S*	A	B	C	D	E
CRX20.050	50	42	143	67	250	290
CRX20.080	80	72	173	97	280	320
CRX20.100	100	92	193	117	300	340



ROLLER CAM UNIT - ROLLENSCHIEBER - CAMMA A RULLO

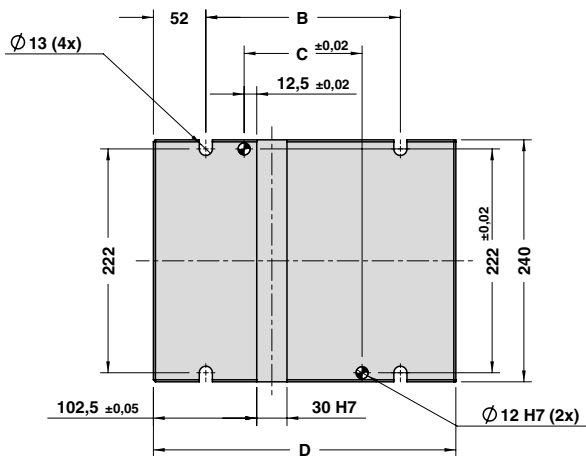

OPTION K

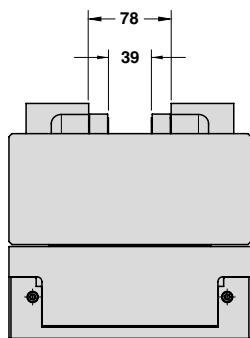
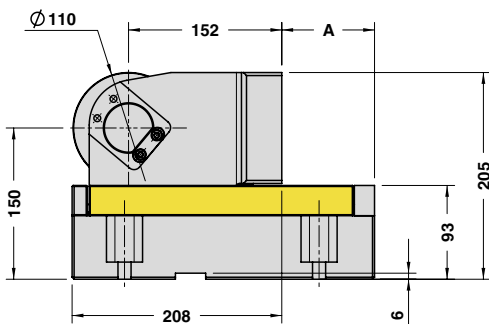
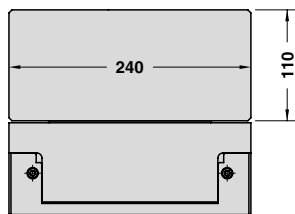

OPTION P

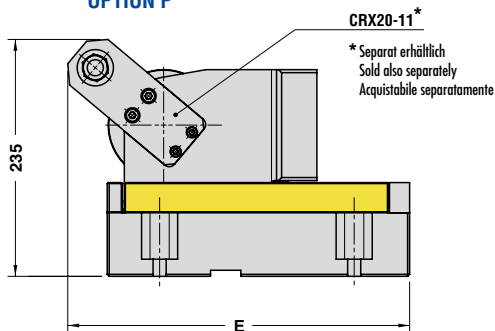



ROLLER CAM UNIT - ROLLENSCHIEBER - CAMMA A RULLO

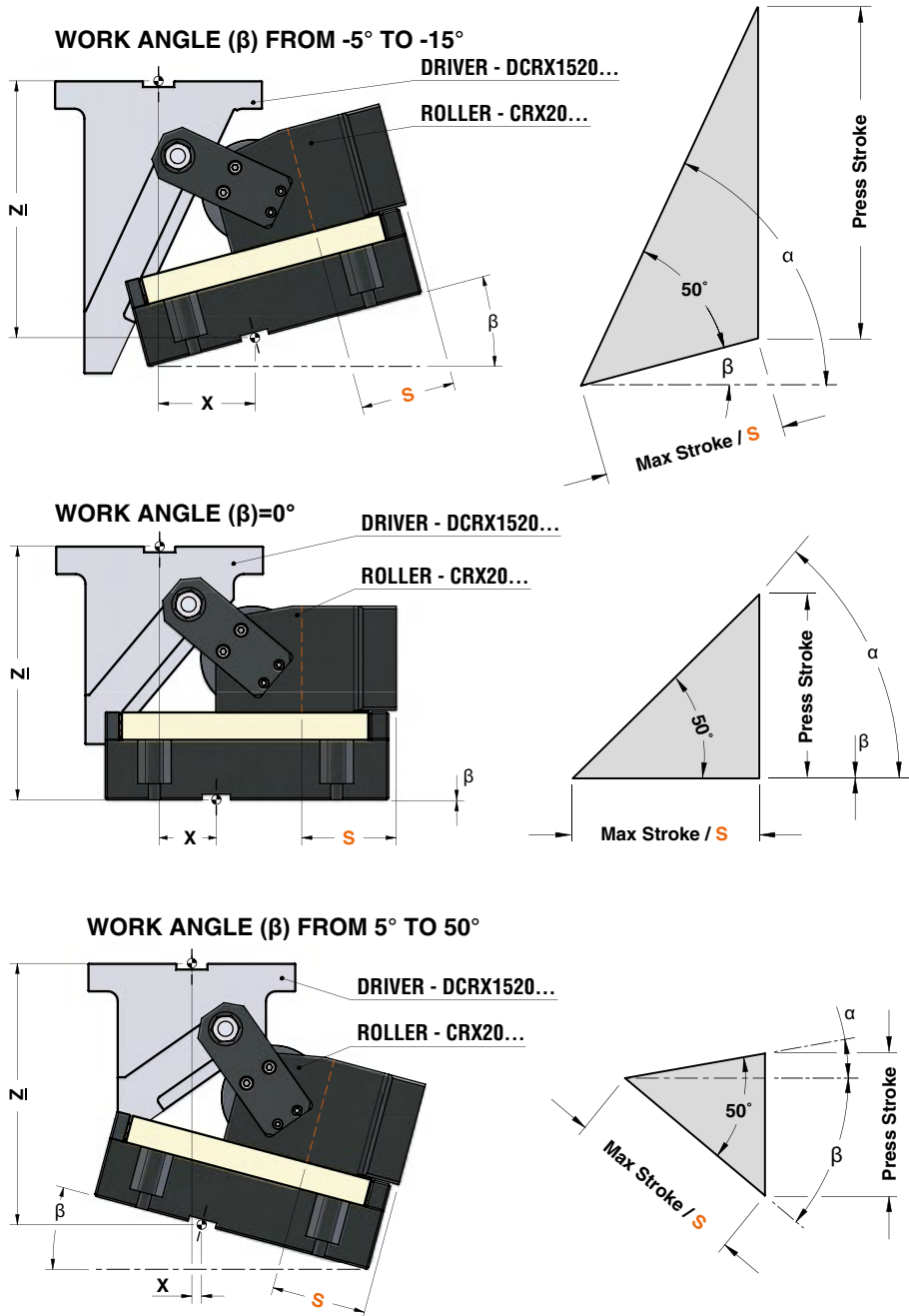



## ROLLER CAM UNIT - ROLLENSCHIEBER - CAMMA A RULLO

ROLLER CAM CODE	Work Angle $\beta$	$\alpha$	Max Stroke S (mm)	Press Stroke (mm)	*CAM DRIVER CODE	X (mm)	Z (mm)
CRX20.050	-15°	65°	50	90,63	DCRX1520.50.H15	127,30	252,52
	-10°	60°	50	76,60	DCRX1520.50.H10	114,24	254,27
	-5°	55°	50	66,78	DCRX1520.50.H05	100,12	255,64
	0°	50°	50	59,59	DCRX1520.50.000	85,06	263,10
	5°	45°	50	54,17	DCRX1520.50.L05	69,15	267,44
	10°	40°	50	50,00	DCRX1520.50.L10	52,53	274,10
	15°	35°	50	46,76	DCRX1520.50.L15	35,31	278,36
	20°	30°	50	44,23	DCRX1520.50.L20	17,64	280,39
	25°	25°	50	42,26	DCRX1520.50.L25	-0,34	275,29
	30°	20°	50	40,76	DCRX1520.50.L30	-18,53	268,15
	35°	15°	50	39,65	DCRX1520.50.L35	-36,76	264,03
	40°	10°	50	38,89	DCRX1520.50.L40	-54,90	257,97
45°	5°	50	38,45	DCRX1520.50.L45	-72,82	250,02	
50°	0°	50	38,30	DCRX1520.50.L50	-90,37	240,22	
CRX20.080	-15°	65°	80	145,01	DCRX1520.80.H15	102,30	308,14
	-10°	60°	80	122,57	DCRX1520.80.H10	89,24	293,31
	-5°	55°	80	106,84	DCRX1520.80.H05	75,13	290,58
	0°	50°	80	95,34	DCRX1520.80.000	60,06	292,35
	5°	45°	80	86,67	DCRX1520.80.L05	44,15	284,94
	10°	40°	80	80,00	DCRX1520.80.L10	27,53	294,11
	15°	35°	80	74,81	DCRX1520.80.L15	10,32	295,31
	20°	30°	80	70,76	DCRX1520.80.L20	-7,35	298,86
	25°	25°	80	67,62	DCRX1520.80.L25	-25,35	289,94
	30°	20°	80	65,22	DCRX1520.80.L30	-43,53	288,70
	35°	15°	80	63,45	DCRX1520.80.L35	-61,76	270,24
	40°	10°	80	62,23	DCRX1520.80.L40	-79,91	259,64
45°	5°	80	61,52	DCRX1520.80.L45	-97,82	246,95	
50°	0°	80	61,28	DCRX1520.80.L50	-115,38	232,25	
CRX20.100	-15°	65°	100	181,26	DCRX1520.80.H15	102,30	271,89
	-10°	60°	100	153,21	DCRX1520.80.H10	89,24	262,67
	-5°	55°	100	133,56	DCRX1520.80.H05	75,12	263,86
	0°	50°	100	119,18	DCRX1520.80.000	60,06	268,51
	5°	45°	100	108,34	DCRX1520.80.L05	44,15	263,27
	10°	40°	100	100,00	DCRX1520.80.L10	27,53	274,10
	15°	35°	100	93,52	DCRX1520.80.L15	10,31	276,60
	20°	30°	100	88,46	DCRX1520.80.L20	-7,35	281,16
	25°	25°	100	84,52	DCRX1520.80.L25	-25,34	273,03
	30°	20°	100	81,52	DCRX1520.80.L30	-43,53	272,39
	35°	15°	100	79,31	DCRX1520.80.L35	-61,76	254,37
	40°	10°	100	77,79	DCRX1520.80.L40	-79,90	244,07
45°	5°	100	76,90	DCRX1520.80.L45	-97,82	231,57	
50°	0°	100	76,60	DCRX1520.80.L50	-115,37	216,92	



ROLLER CAM UNIT - ROLLENSCHIEBER - CAMMA A RULLO

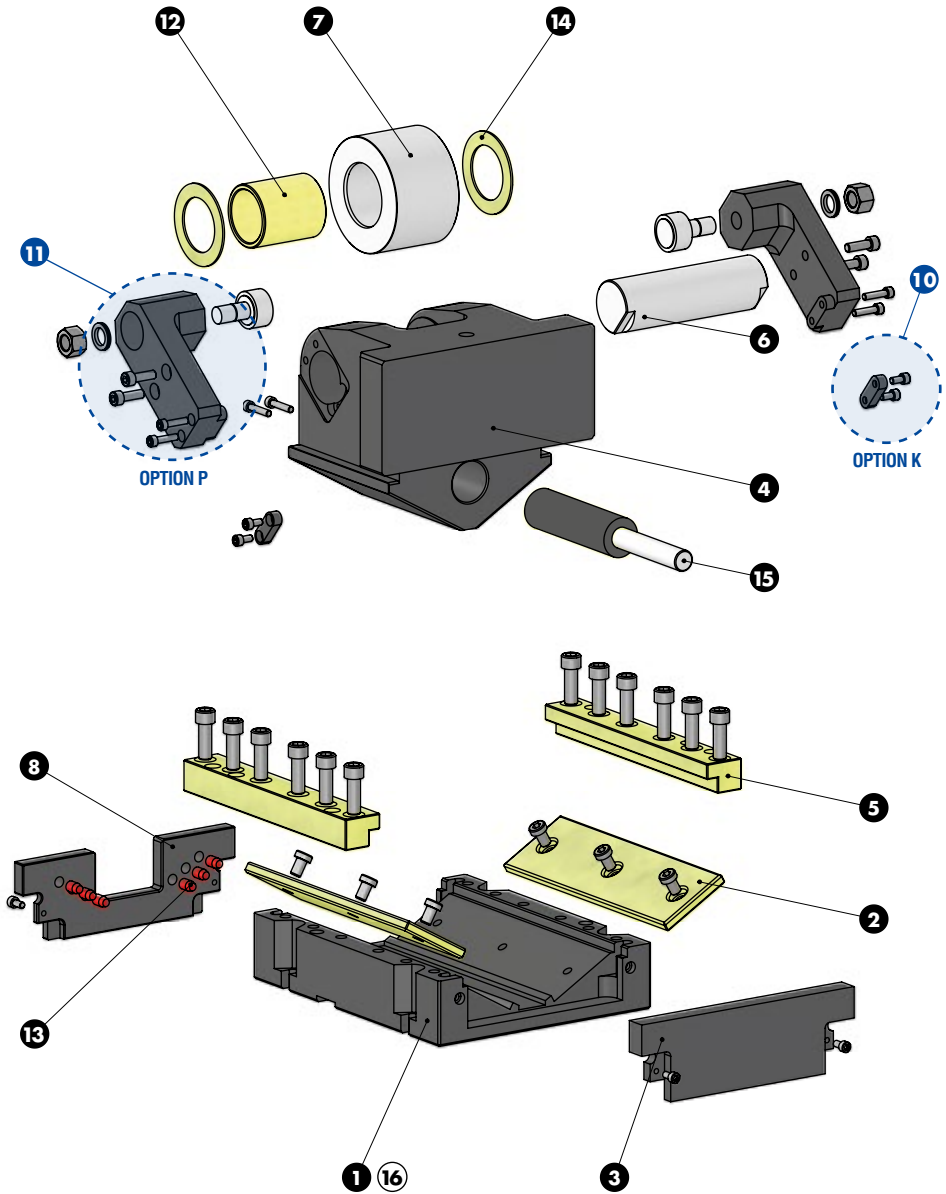



## ROLLER CAM UNIT - ROLLENSCHIEBER - CAMMA A RULLO

### SLIDER STRUCTURE AND CLEARANCES

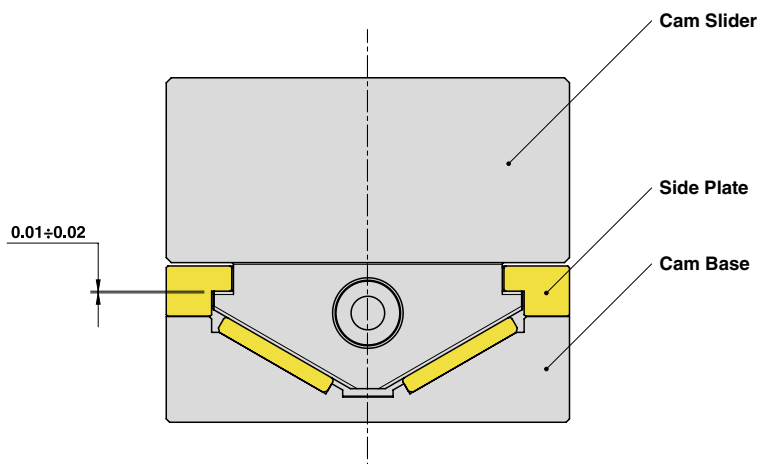

### PART LIST

Particular number	Description	Material	Quantity
1	Cam Base	CK45	1
2	Wear Plate	CuZn25Al5 + Graphite - HB > 190	2
3	Gas Spring Stopper Plate	CK45	1
4	Cam Slider	CK45	1
5	Side Plate	CuZn25Al5 + Graphite - HB > 190	2
6	Pin	16NiCrMo4	1
7	Roller	100Cr6	1
8	Stopper Plate	CK45	1
10	Key - <b>OPTION K</b>	CK45	2
11	Positive Return + Roller KRV35PPA - <b>OPTION P</b>	CK45	2
12	Self-Lubricating Bush	CuZn25Al5 + Graphite - HB > 190	1
13	Elastomer Cap	Elastomer 92SH	6
14	Washer PCMW 52780.2M	-	2
15	Gas Spring	-	1
16	Cam Base Fixing Screws M12x35 DIN 912	-	4

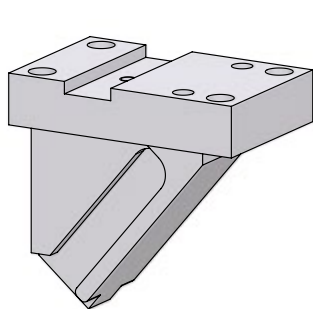

**ROLLER CAM DRIVER - TREIBER FÜR ROLLENSCHIEBER - CUNEO PER CAMME A RULLO**

For driver positioning see pages 852-853  
 Positionierung des Treibers siehe Seiten 852-853  
 Per posizionamento cuneo vedi pagine 852-853

STOCK		Art.	Stroke = 30	Work angle = 0°
		DCRX0100	30	000

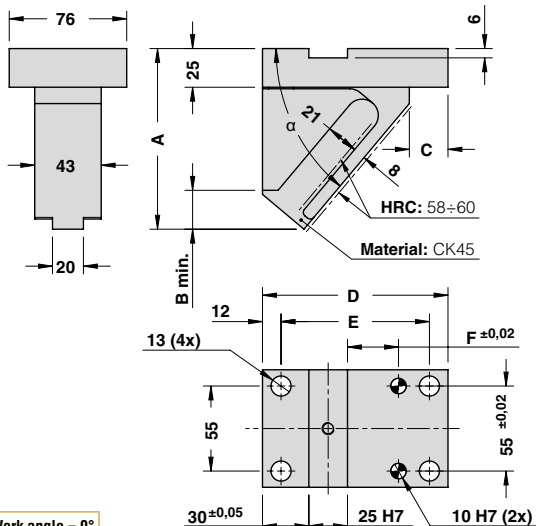

OMCR CODE	ROLLER CAM MODEL	Stroke (mm)	Work Angle	Overall Dimensions (mm)						
				S	β	α	A	B min.	C	D
DCRX0100.30.H15	CRX01.030	30	-15°	65°	131	18	30	100	76	13
DCRX0100.30.H10		30	-10°	60°	113,5	20,5	30	100	76	13
DCRX0100.30.H05		30	-5°	55°	97	22,5	30	100	76	13
DCRX0100.30.000		30	0°	50°	92,5	24,5	30	100	76	13
DCRX0100.30.L05		30	5°	45°	82	26,5	30	100	76	13
DCRX0100.30.L10		30	10°	40°	78,5	28	30	100	76	13
DCRX0100.30.L15		30	15°	35°	75,5	29,5	30	100	76	13
DCRX0100.30.L20		30	20°	30°	74	31	30	100	76	13
DCRX0100.30.L25		30	25°	25°	70,5	34,5	30	100	76	13
DCRX0100.30.L30		30	30°	20°	70	33	30	100	76	13
DCRX0100.30.L35		30	35°	15°	69	32	30	100	76	13
DCRX0100.30.L40		30	40°	10°	65	32	30	100	76	13
DCRX0100.30.L45		30	45°	5°	62	30,5	30	100	76	13
DCRX0100.30.L50		30	50°	0°	59,5	29	30	100	76	13
DCRX0100.50.H15		CRX01.050	50	-15°	65°	179	16	25	120	96
DCRX0100.50.H10	50		-10°	60°	153,5	20,5	25	120	96	33
DCRX0100.50.H05	50		-5°	55°	142	22,5	25	120	96	33
DCRX0100.50.000	50		0°	50°	116	24,5	25	120	96	33
DCRX0100.50.L05	50		5°	45°	111	26,5	25	120	96	33
DCRX0100.50.L10	50		10°	40°	101,5	31	25	120	96	33
DCRX0100.50.L15	50		15°	35°	99	33	25	120	96	33
DCRX0100.50.L20	50		20°	30°	93	33	25	120	96	33
DCRX0100.50.L25	50		25°	25°	87,5	30,5	25	120	96	33
DCRX0100.50.L30	50		30°	20°	83	29,5	25	120	96	33
DCRX0100.50.L35	50		35°	15°	84	30,5	25	120	96	33
DCRX0100.50.L40	50		40°	10°	75	31	25	120	96	33
DCRX0100.50.L45	50		45°	5°	72	31,5	25	120	96	33
DCRX0100.50.L50	50		50°	0°	69,5	29	25	120	96	33



FUNCTIONING EXAMPLE FOR WORK ANGLE ( $\beta$ ) FROM  $-5^\circ$  TO  $-15^\circ$

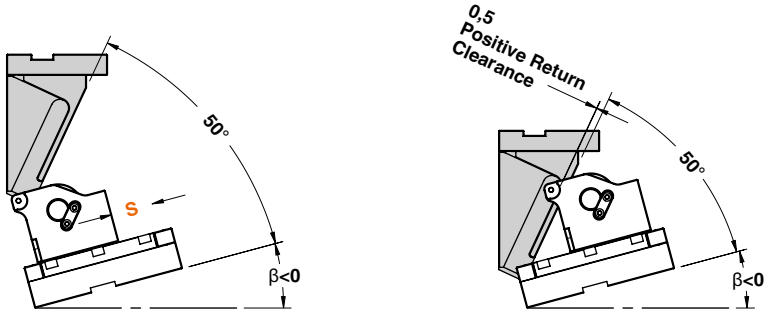

FUNCTIONING EXAMPLE FOR WORK ANGLE ( $\beta$ )=0°

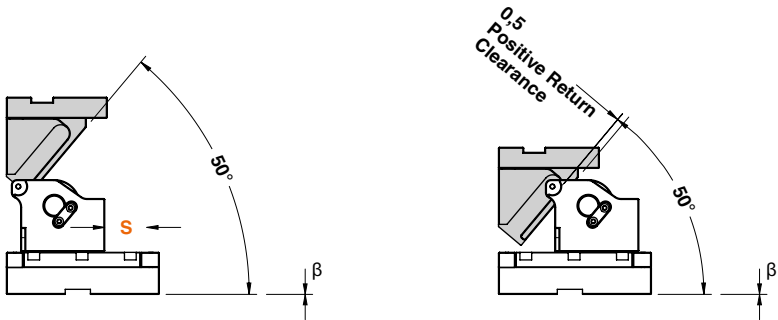

FUNCTIONING EXAMPLE FOR WORK ANGLE ( $\beta$ ) FROM  $5^\circ$  TO  $50^\circ$

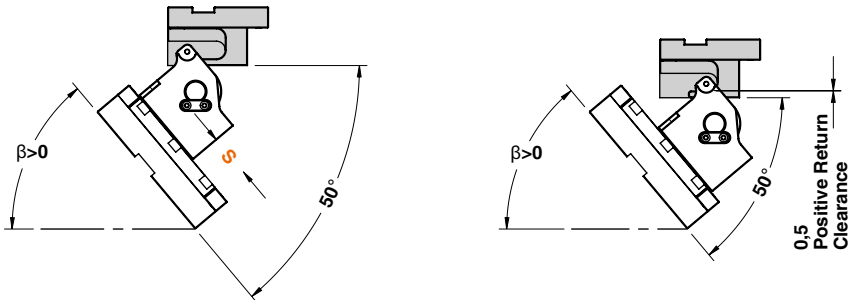

Cam Units CRX



ROLLER CAM DRIVER - TREIBER FÜR ROLLENSCHIEBER - CUNEO PER CAMME A RULLO

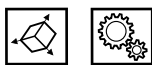
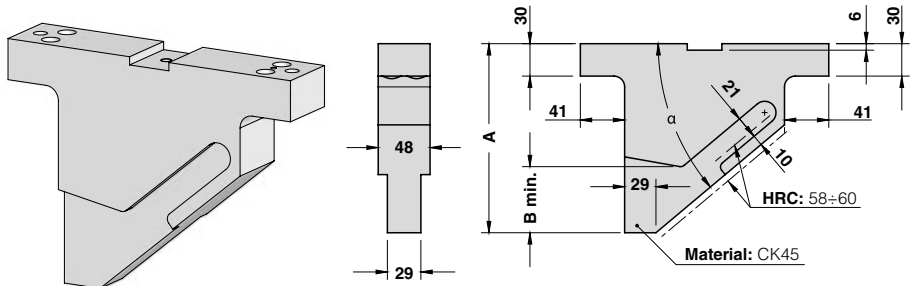

For driver positioning see pages 858-859 and 864-865  
 Positionierung des Treibers siehe Seiten 858-859 und 864-865  
 Per posizionamento cuneo vedi pagine 858-859 e 864-865

STOCK	ORDER EXAMPLE	Art.	Stroke = 50	Work angle = 0°
		DCRX0305	50	000

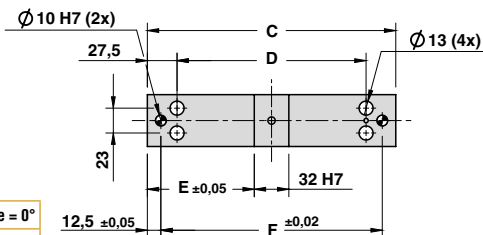

OMCR CODE	ROLLER CAM MODEL	Stroke (mm)	Work Angle	Overall Dimensions (mm)						
		S	β	α	A	B min.	C	D	E	F
DCRX0305.50.H15	CRX03.050 CRX05.050	50	-15°	65°	185	70	180	125	74	155
DCRX0305.50.H10		50	-10°	60°	165	70	180	125	74	155
DCRX0305.50.H05		50	-5°	55°	155	60	180	125	74	155
DCRX0305.50.000		50	0°	50°	145	50	180	125	74	155
DCRX0305.50.L05		50	5°	45°	135	40	180	125	74	155
DCRX0305.50.L10		50	10°	40°	130	35	180	125	74	155
DCRX0305.50.L15		50	15°	35°	125	30	180	125	74	155
DCRX0305.50.L20		50	20°	30°	120	25	180	125	74	155
DCRX0305.50.L25		50	25°	25°	110	40	180	125	74	155
DCRX0305.50.L30		50	30°	20°	100	30	180	125	74	155
DCRX0305.50.L35		50	35°	15°	95	25	180	125	74	155
DCRX0305.50.L40		50	40°	10°	90	20	180	125	74	155
DCRX0305.50.L45		50	45°	5°	85	25	180	125	74	155
DCRX0305.50.L50		50	50°	0°	80	30	180	125	74	155
DCRX0305.80.H15		CRX03.080 CRX03.100 CRX05.080 CRX05.100	80-100	-15°	65°	280	160	230	175	99
DCRX0305.80.H10	80-100		-10°	60°	250	130	230	175	99	205
DCRX0305.80.H05	80-100		-5°	55°	220	100	230	175	99	205
DCRX0305.80.000	80-100		0°	50°	200	80	230	175	99	205
DCRX0305.80.L05	80-100		5°	45°	180	60	230	175	99	205
DCRX0305.80.L10	80-100		10°	40°	175	55	230	175	99	205
DCRX0305.80.L15	80-100		15°	35°	170	50	230	175	99	205
DCRX0305.80.L20	80-100		20°	30°	165	45	230	175	99	205
DCRX0305.80.L25	80-100		25°	25°	155	65	230	175	99	205
DCRX0305.80.L30	80-100		30°	20°	145	55	230	175	99	205
DCRX0305.80.L35	80-100		35°	15°	130	50	230	175	99	205
DCRX0305.80.L40	80-100		40°	10°	115	55	230	175	99	205
DCRX0305.80.L45	80-100		45°	5°	105	45	230	175	99	205
DCRX0305.80.L50	80-100		50°	0°	95	55	230	175	99	205

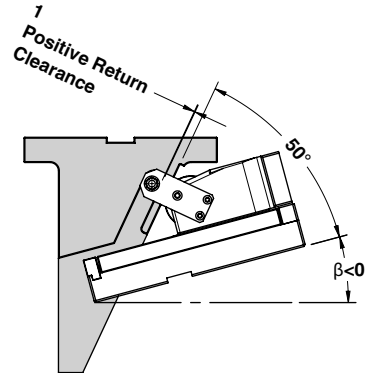
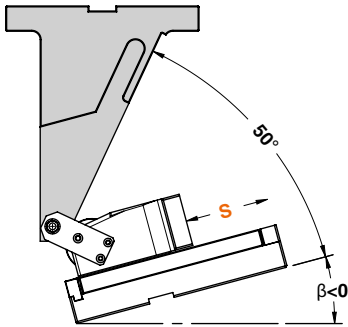
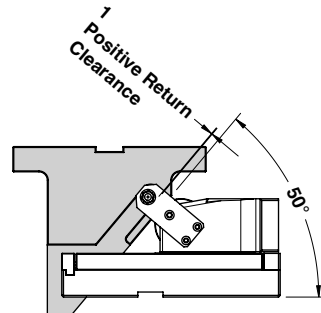
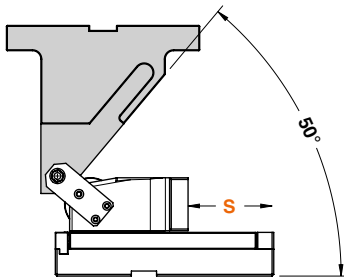
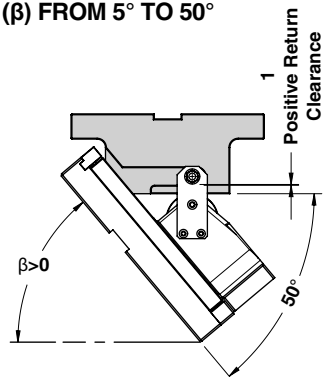
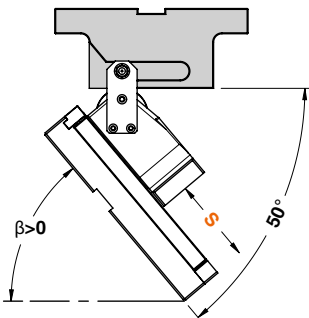
**ROLLER CAM DRIVER - TREIBER FÜR ROLLENSCHIEBER - CUNEO PER CAMME A RULLO**
**FUNCTIONING EXAMPLE FOR WORK ANGLE ( $\beta$ ) FROM  $-5^\circ$  TO  $-15^\circ$** 

**FUNCTIONING EXAMPLE FOR WORK ANGLE ( $\beta$ ) =  $0^\circ$** 

**FUNCTIONING EXAMPLE FOR WORK ANGLE ( $\beta$ ) FROM  $5^\circ$  TO  $50^\circ$** 

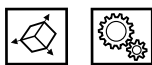
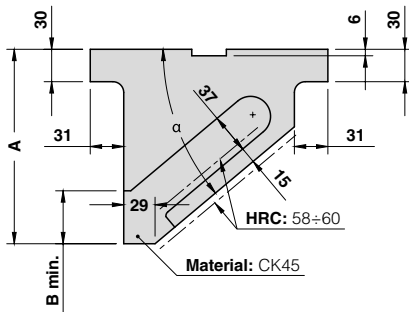
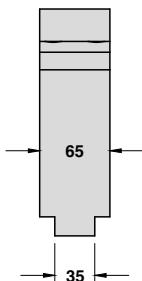
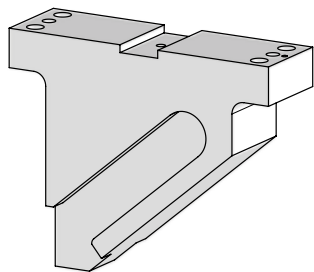

ROLLER CAM DRIVER - TREIBER FÜR ROLLENSCHIEBER - CUNEO PER CAMME A RULLO



For driver positioning see pages 870-871 and 876-877  
 Positionierung des Treibers siehe Seiten 870-871 und 876-877  
 Per posizionamento cuneo vedi pagine 870-871 e 876-877

STOCK	ORDER EXAMPLE	Art.	Stroke = 50	Work angle = 0°
		DCRX1520	50	000

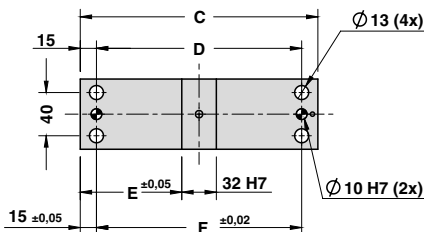

OMCR CODE	ROLLER CAM MODEL	Stroke (mm)	Work Angle	Overall Dimensions (mm)						
				S	β	α	A	B min.	C	D
DCRX1520.50.H15	CRX15.050 CRX20.050	50	-15°	65°	200	66	170	140	69	140
DCRX1520.50.H10		50	-10°	60°	175	59	170	140	69	140
DCRX1520.50.H05		50	-5°	55°	155	55	170	140	69	140
DCRX1520.50.000		50	0°	50°	145	52	170	140	69	140
DCRX1520.50.L05		50	5°	45°	135	50	170	140	69	140
DCRX1520.50.L10		50	10°	40°	130	49	170	140	69	140
DCRX1520.50.L15		50	15°	35°	125	49	170	140	69	140
DCRX1520.50.L20		50	20°	30°	120	49	170	140	69	140
DCRX1520.50.L25		50	25°	25°	110	49	170	140	69	140
DCRX1520.50.L30		50	30°	20°	100	50	170	140	69	140
DCRX1520.50.L35		50	35°	15°	95	52	170	140	69	140
DCRX1520.50.L40		50	40°	10°	90	53	170	140	69	140
DCRX1520.50.L45		50	45°	5°	85	50	170	140	69	140
DCRX1520.50.L50		50	50°	0°	80	0	170	140	69	140
DCRX1520.80.H15		CRX15.080 CRX15.100 CRX20.080 CRX20.100	80-100	-15°	65°	310	66	220	190	94
DCRX1520.80.H10	80-100		-10°	60°	260	59	220	190	94	190
DCRX1520.80.H05	80-100		-5°	55°	230	55	220	190	94	190
DCRX1520.80.000	80-100		0°	50°	210	52	220	190	94	190
DCRX1520.80.L05	80-100		5°	45°	185	50	220	190	94	190
DCRX1520.80.L10	80-100		10°	40°	180	49	220	190	94	190
DCRX1520.80.L15	80-100		15°	35°	170	49	220	190	94	190
DCRX1520.80.L20	80-100		20°	30°	165	49	220	190	94	190
DCRX1520.80.L25	80-100		25°	25°	150	49	220	190	94	190
DCRX1520.80.L30	80-100		30°	20°	145	50	220	190	94	190
DCRX1520.80.L35	80-100		35°	15°	125	52	220	190	94	190
DCRX1520.80.L40	80-100		40°	10°	115	53	220	190	94	190
DCRX1520.80.L45	80-100		45°	5°	105	50	220	190	94	190
DCRX1520.80.L50	80-100		50°	0°	95	52	220	190	94	190





ROLLER CAM DRIVER - TREIBER FÜR ROLLENSCHIEBER - CUNEO PER CAMME A RULLO

FUNCTIONING EXAMPLE FOR WORK ANGLE ( $\beta$ ) FROM  $-5^\circ$  TO  $-15^\circ$

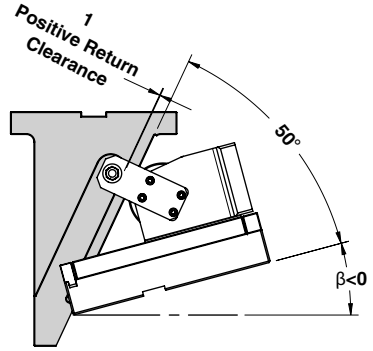
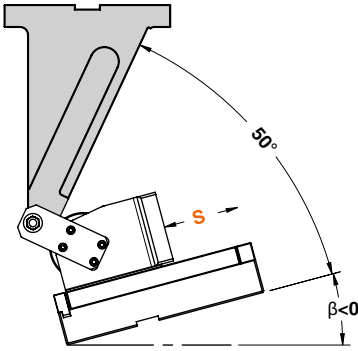

FUNCTIONING EXAMPLE FOR WORK ANGLE ( $\beta$ )= $0^\circ$

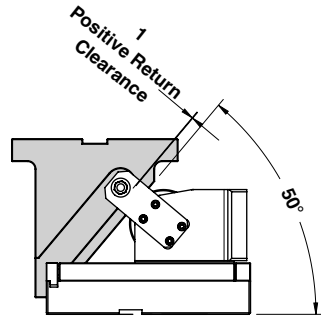
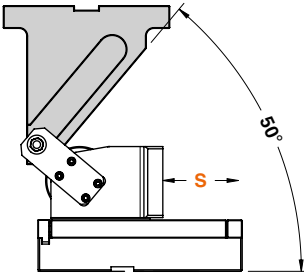

FUNCTIONING EXAMPLE FOR WORK ANGLE ( $\beta$ ) FROM  $5^\circ$  TO  $50^\circ$

